

design and development

SITE ANALYSIS
ADDITIONAL CONSIDERATIONS



washrooms at campus martius
for skaters only
this is a very public set, but
with very few public amenities



portable toilets are located
throughout the city.
however, they are in marginal
spaces such as sidewalks and in
alleyways, rather than placed as
a celebrated public service.
there is a potential for public
amenities, however they exist in
the margins such as the streets
and sidewalks.



there is a potential for public
amenities, however they exist in
the margins such as the streets
and sidewalks.
the steam on griswold takes up
the street space and traffic goes
around it.



detroit commerce building demo-
lition adjacent to griswold site
will be future home of park-
ing lot and private condos. the
changing detroit seeks the cre-
ative class with higher incomes.
nothing wrong with that. but
what's for the common person?
what's being created for the gen-
eral public?

Bench Study

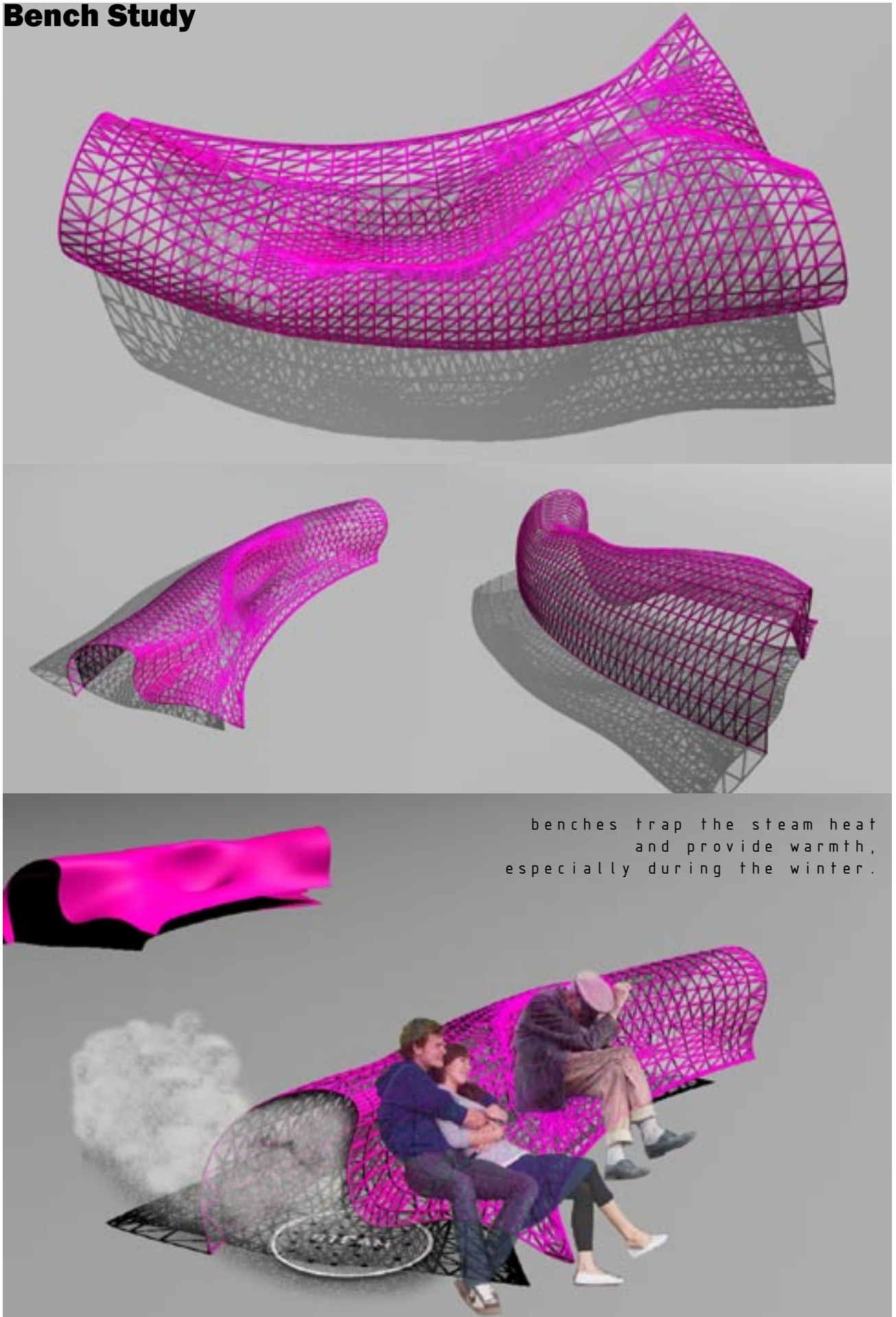

Media Hub Study



by adding a newsstand and a media post with tv screens, the public space becomes more dynamic because people are encouraged to stay a bit. the media is also a method of mass communication to the general public. it's relevance and the topics being covered are the catalysts for public discussion and response.





media hub and washroom at different locations



Car Wash Study

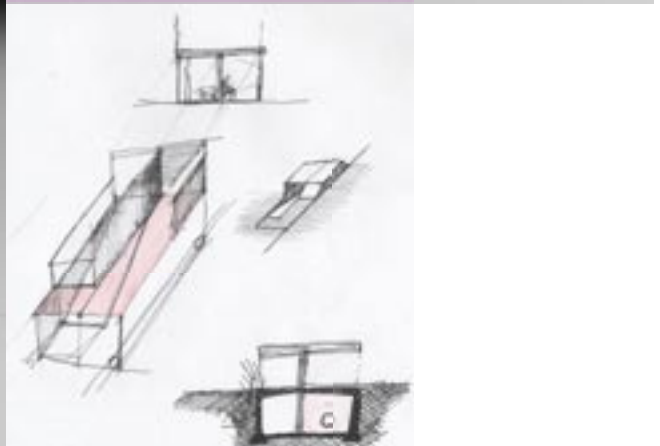
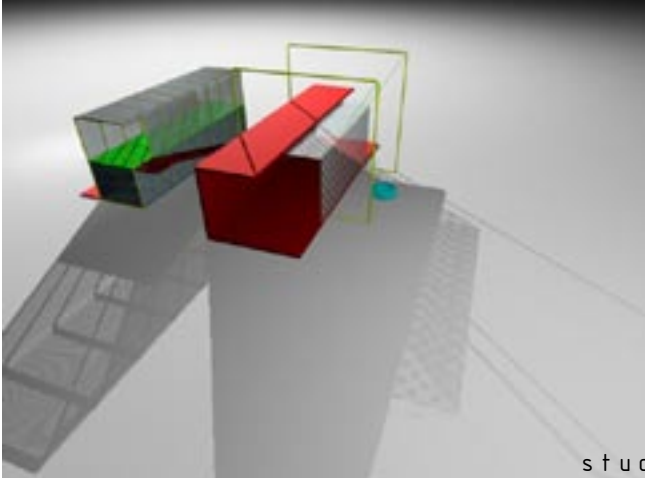
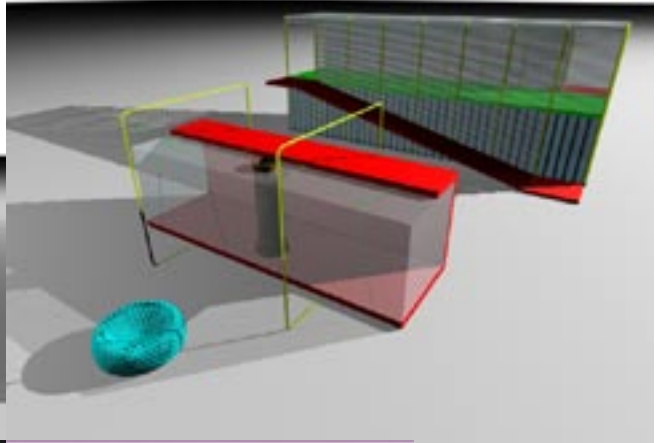
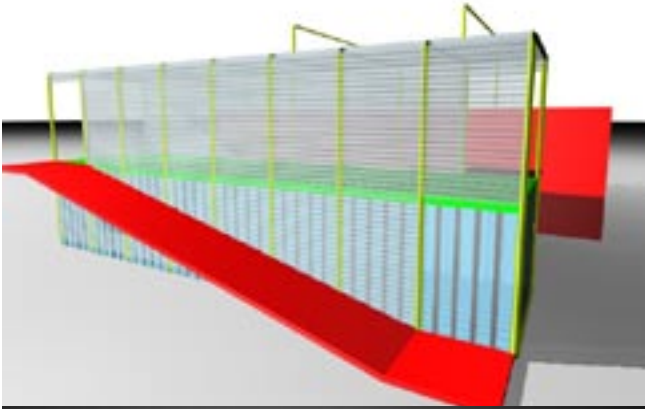

studies for car wash at griswold site.

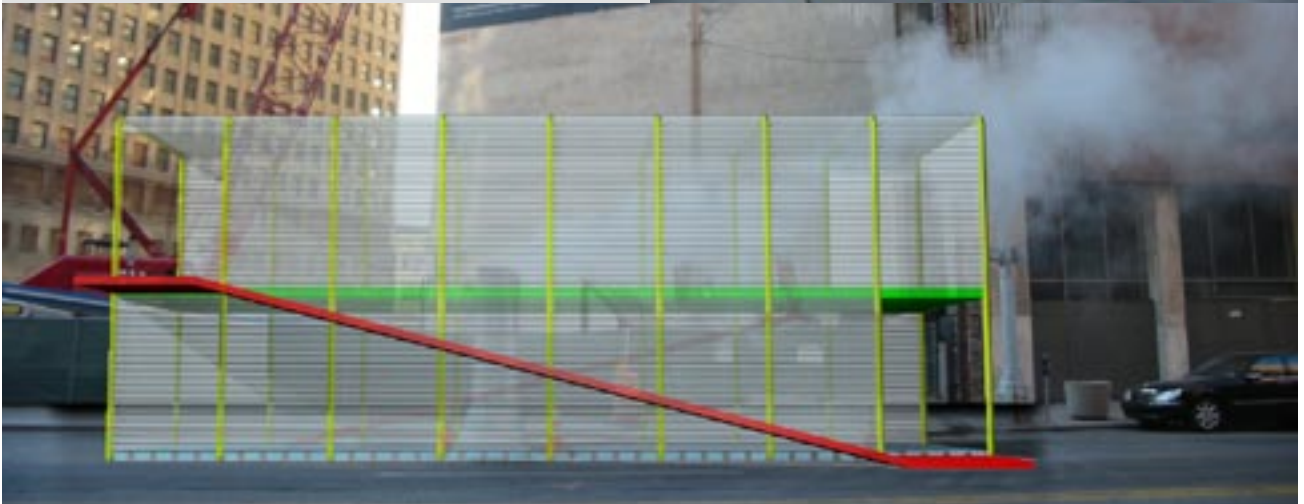
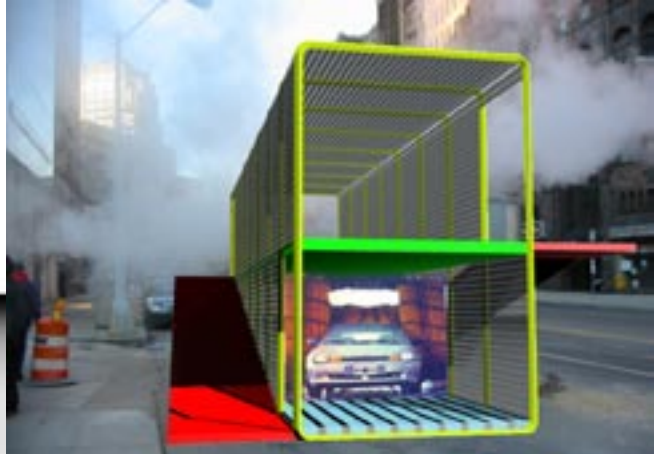
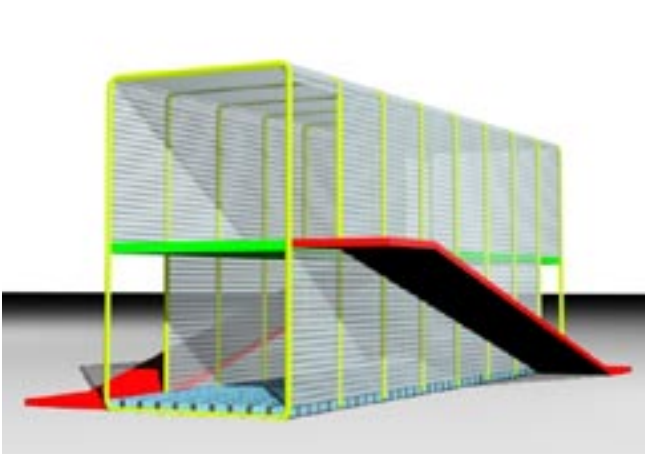

Structural Studies

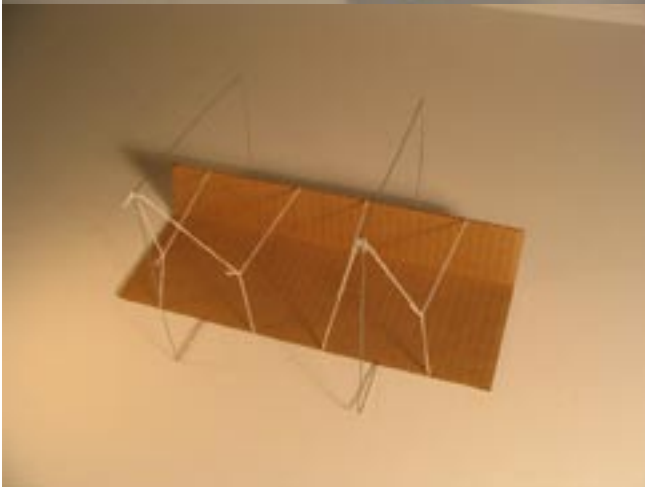
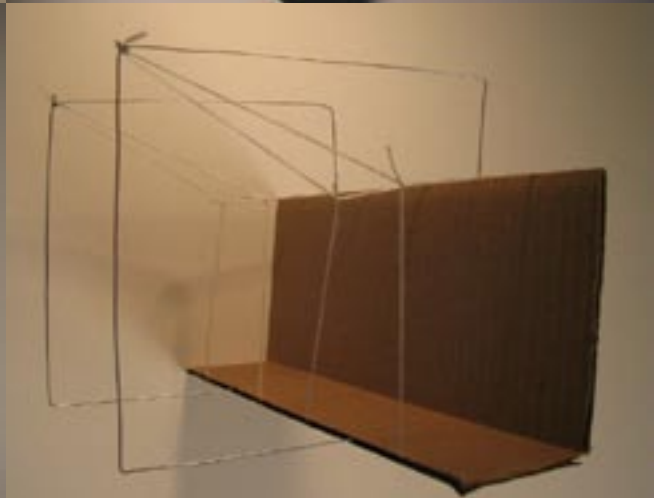
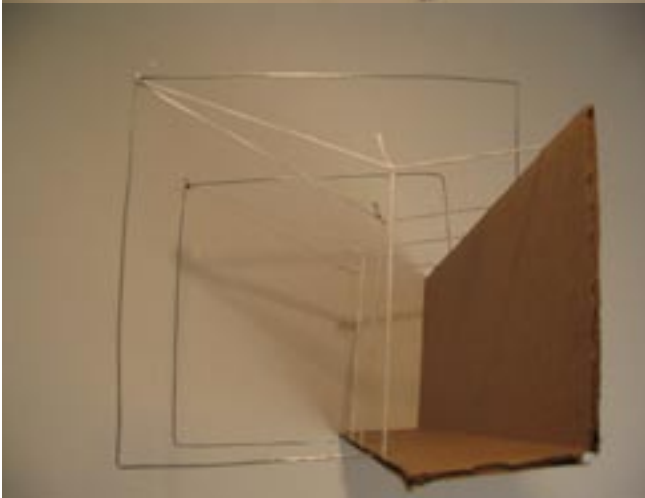
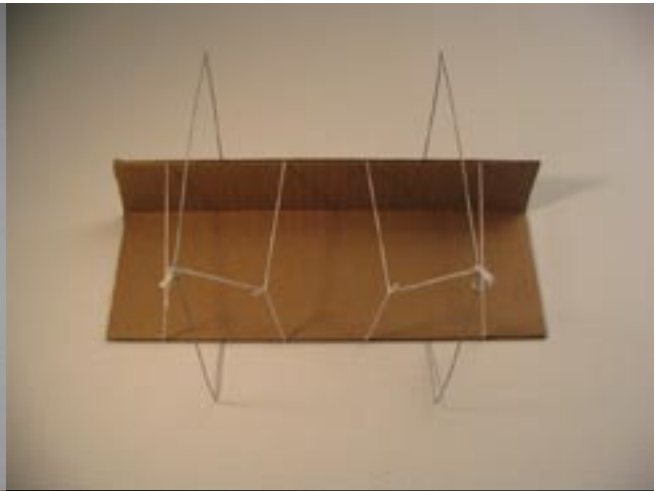

Car Wash Study

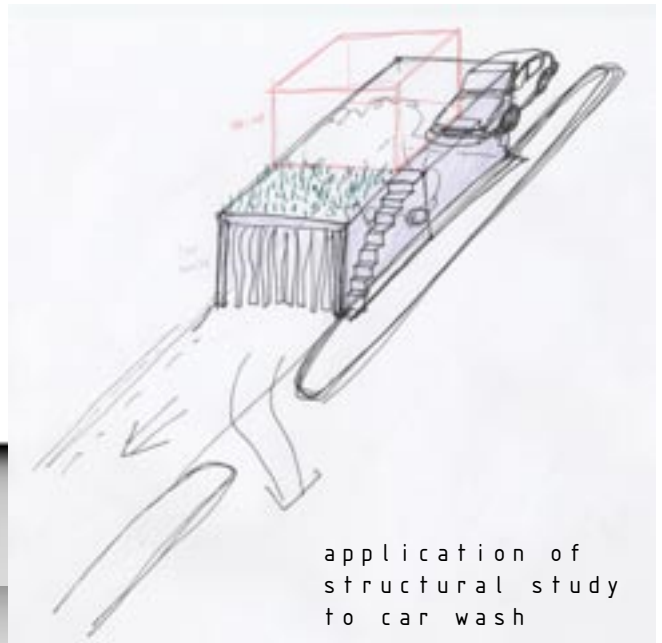
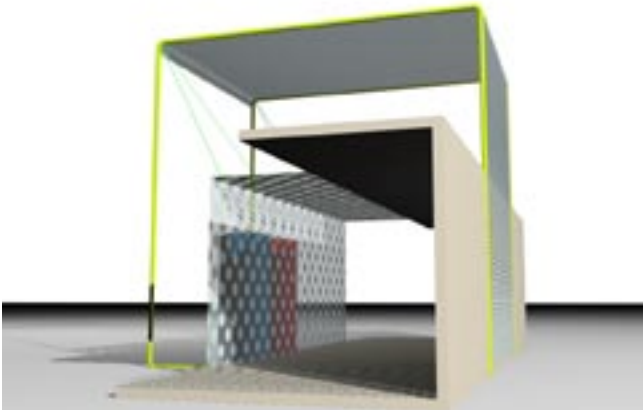

application of
structural study
to car wash

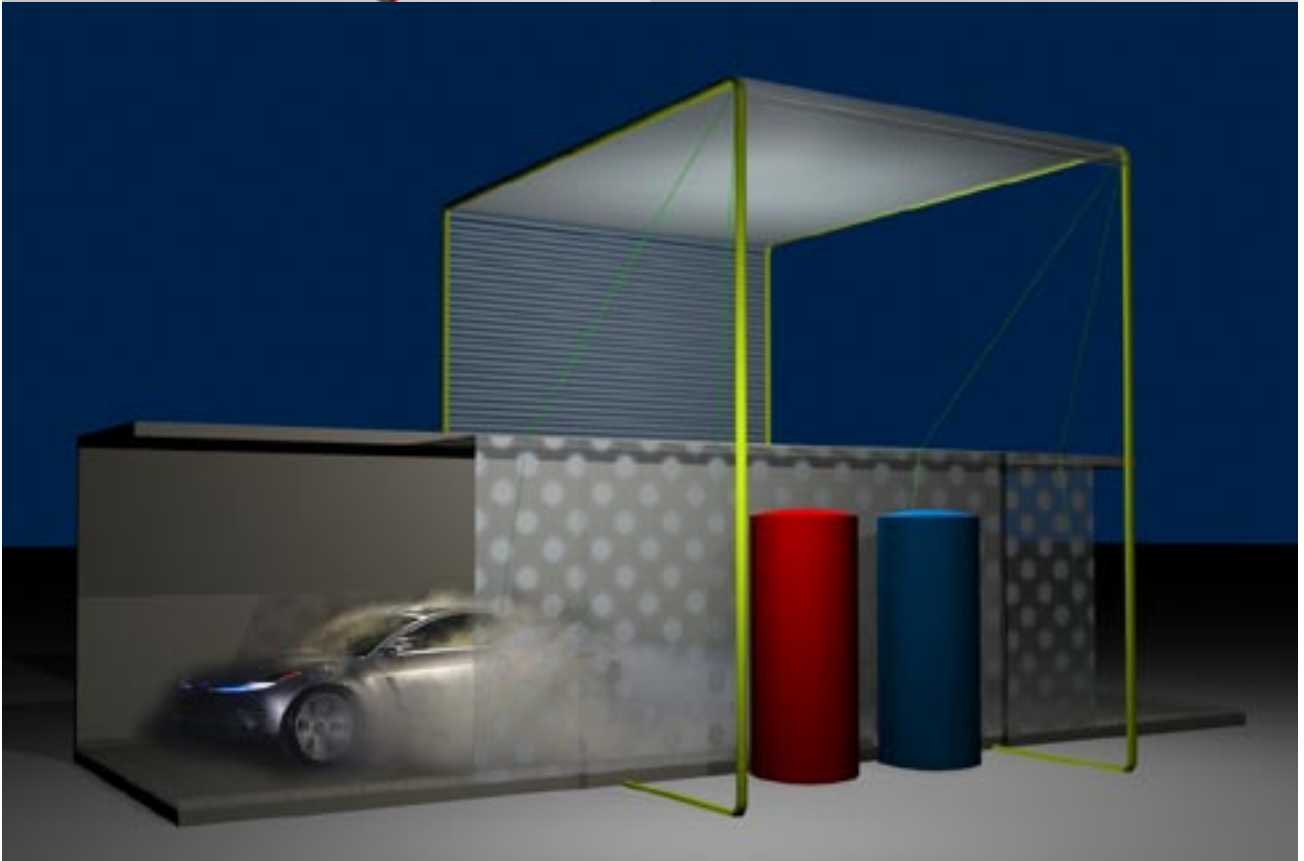
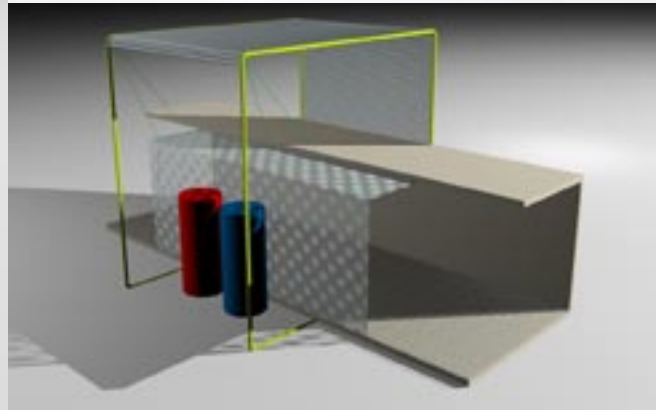
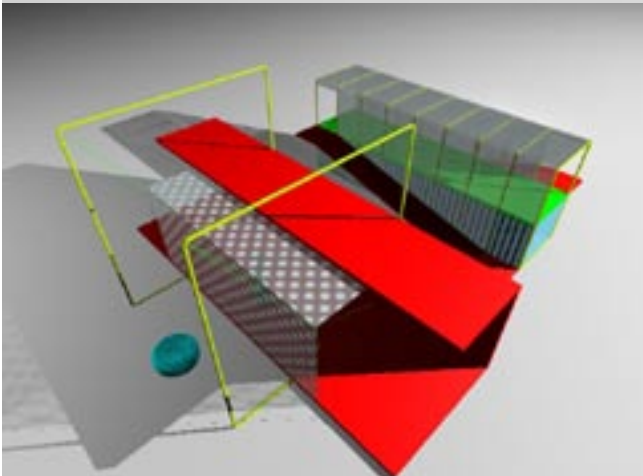

Steam Washroom Study

steam pipe provides heat and water for washroom.

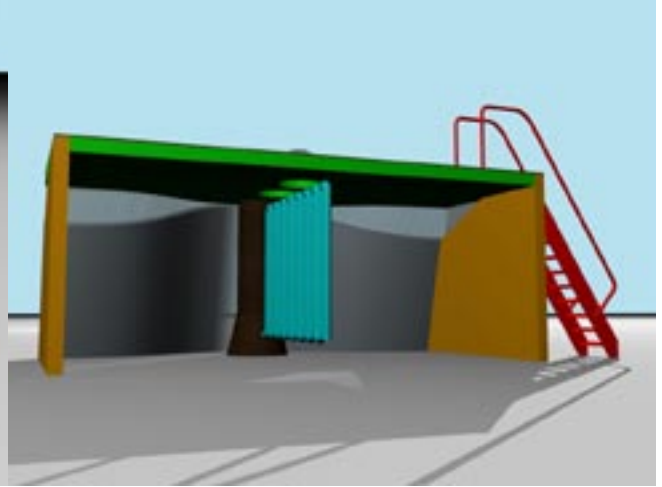
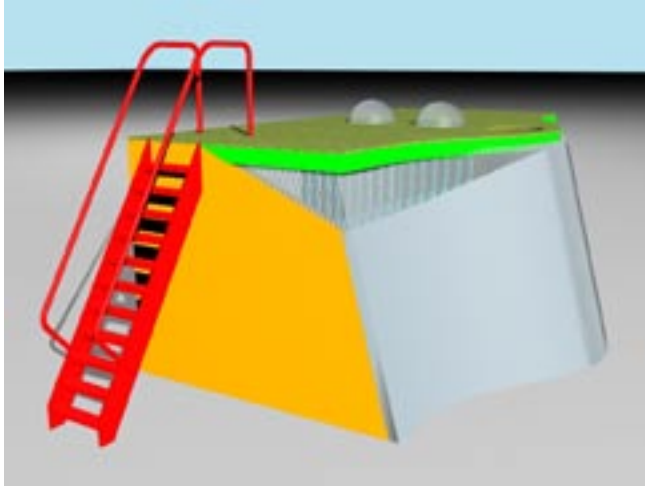
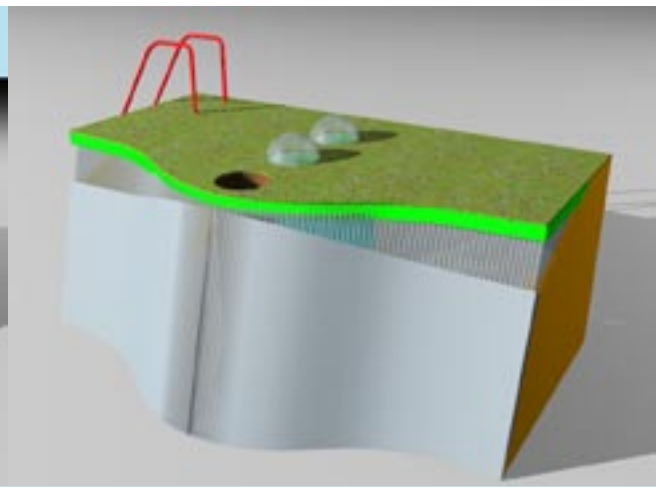
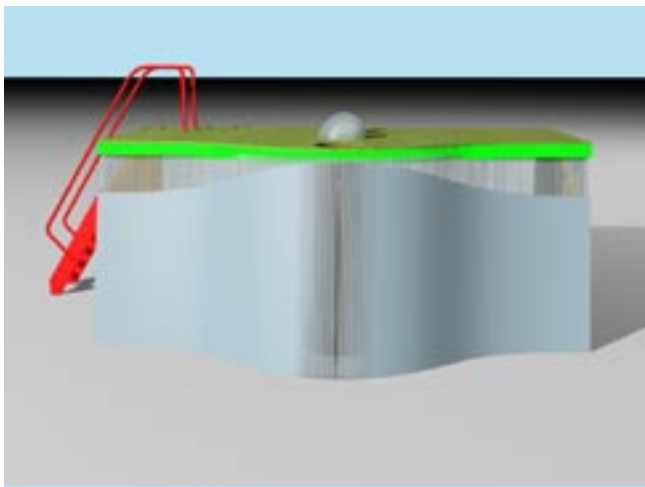
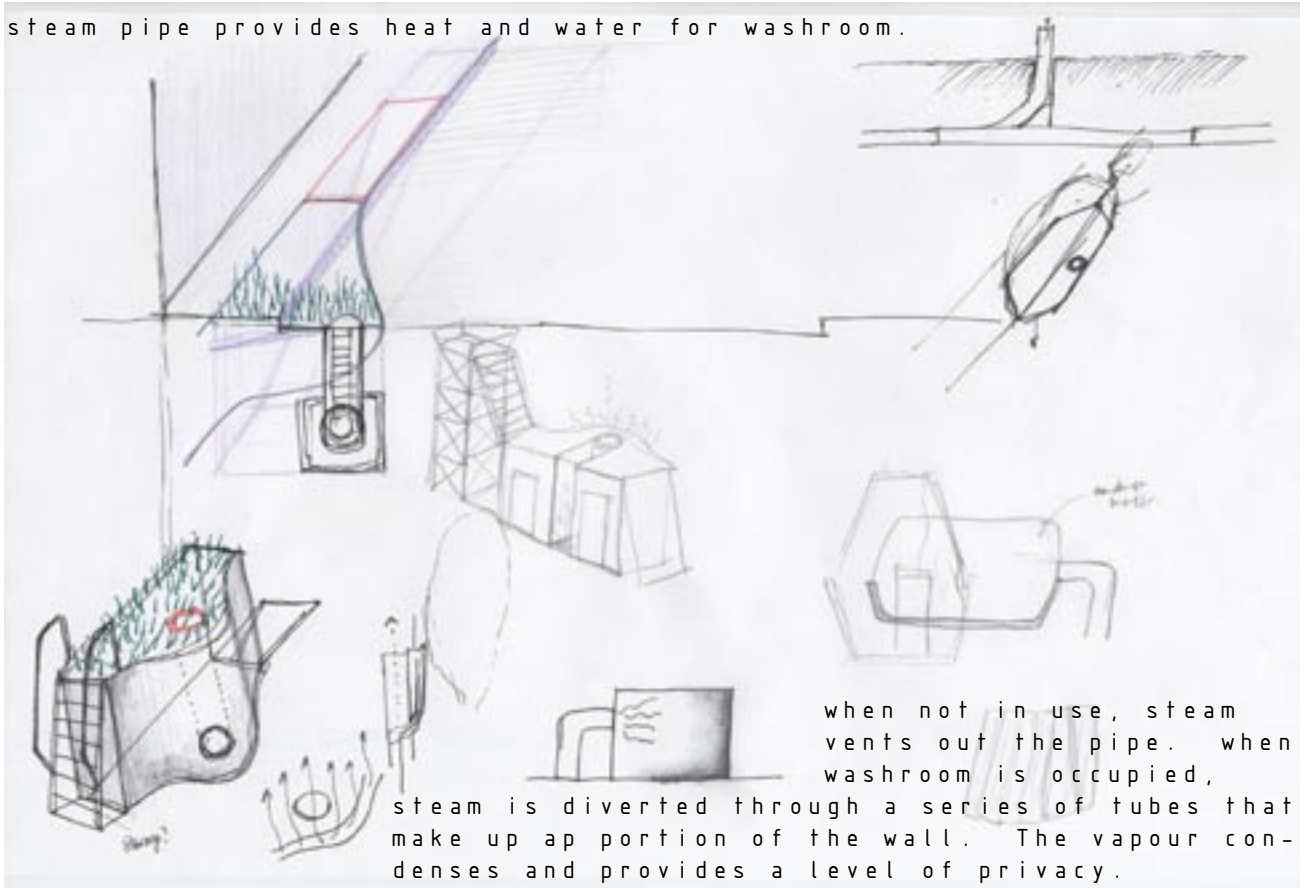

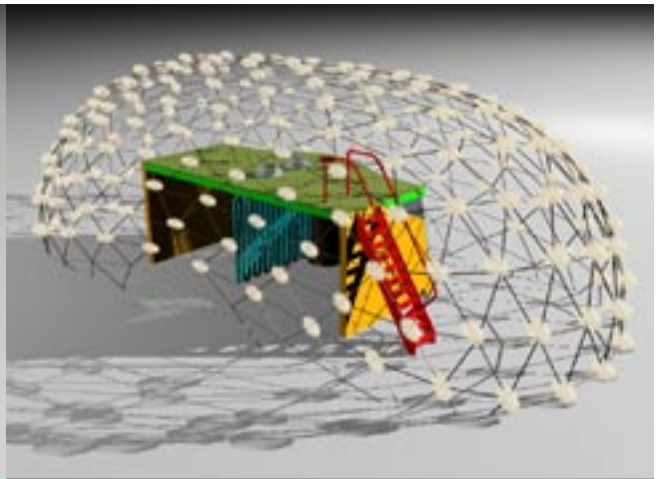
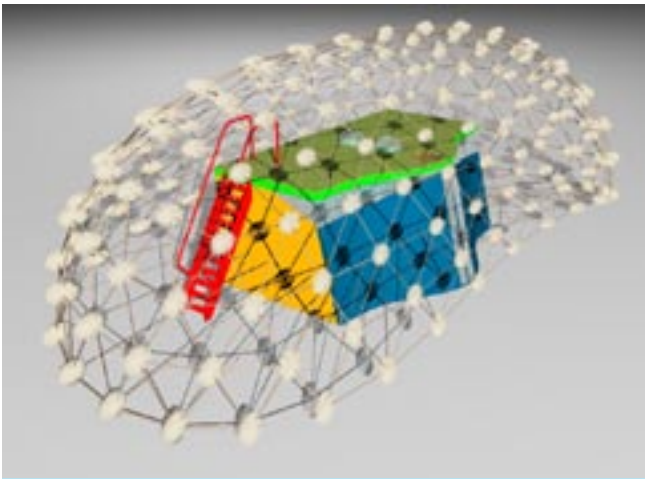

geodesic lighting scheme illuminates and clearly defines this public washroom space. as a method of marking a contested space, the lights make the space very distinct.

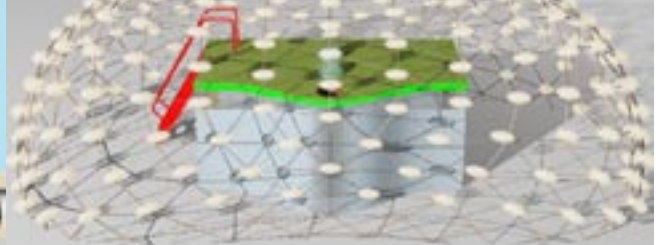
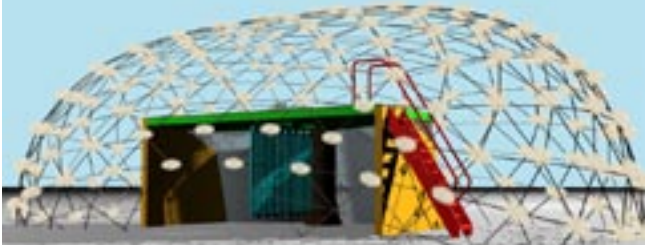

perhaps it is good to claim the space, but perhaps it also limits the definition of the public domain.

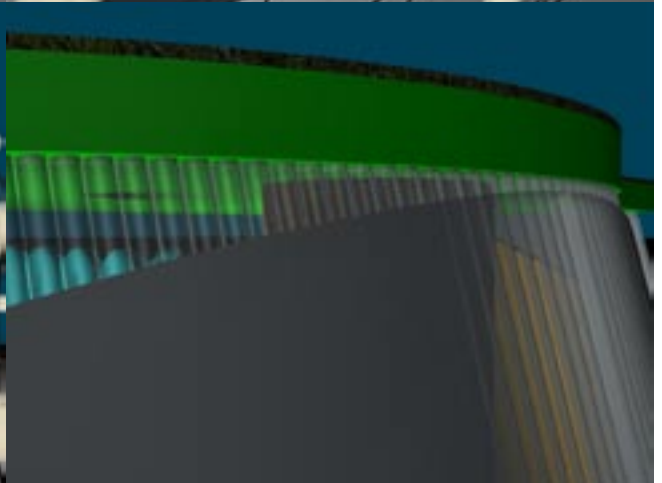
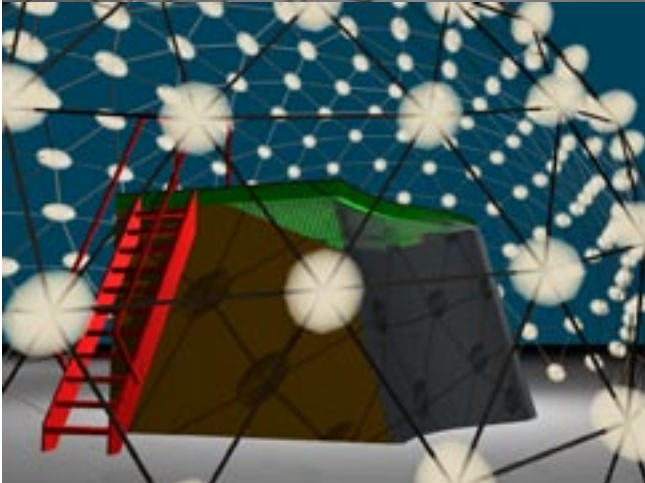
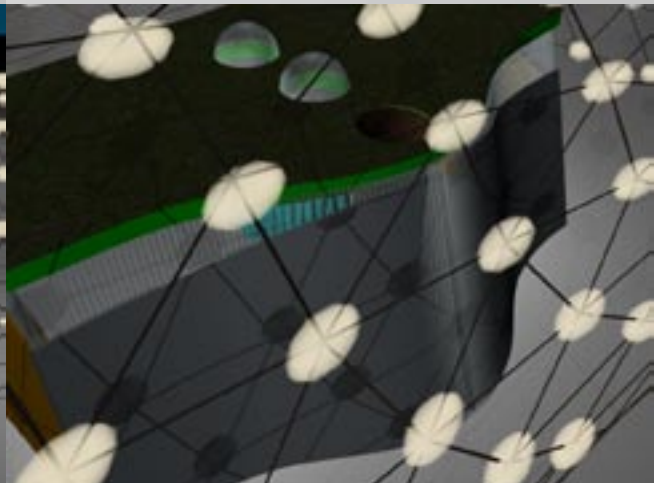
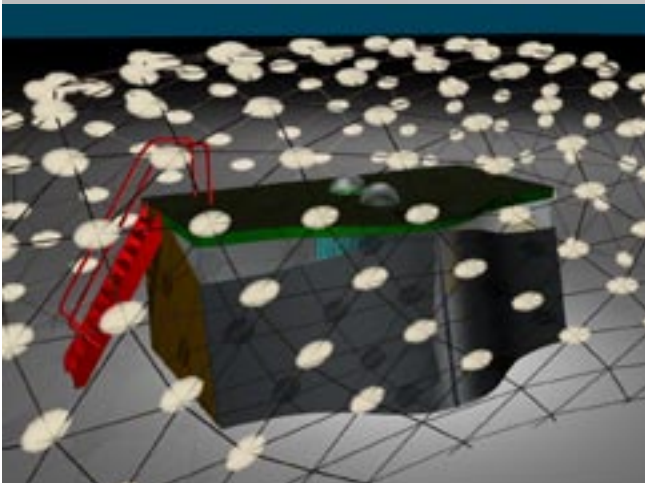

Pod Study

Pods are small enclosures that can be arranged to explore the relationship between private and public space.

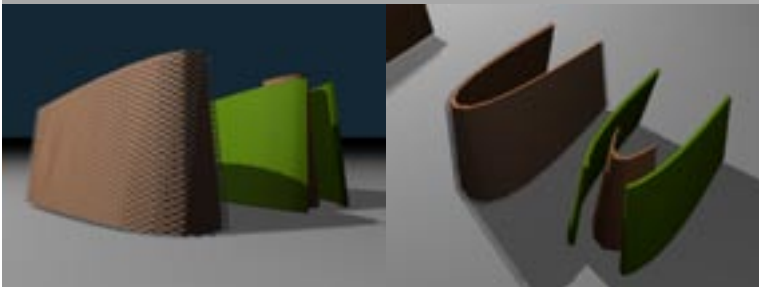
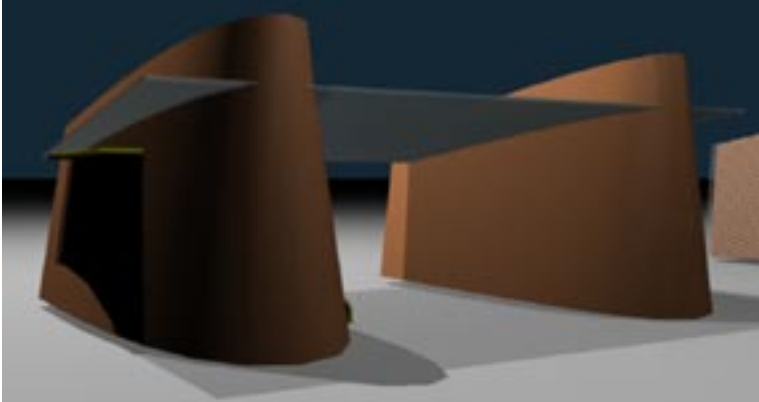
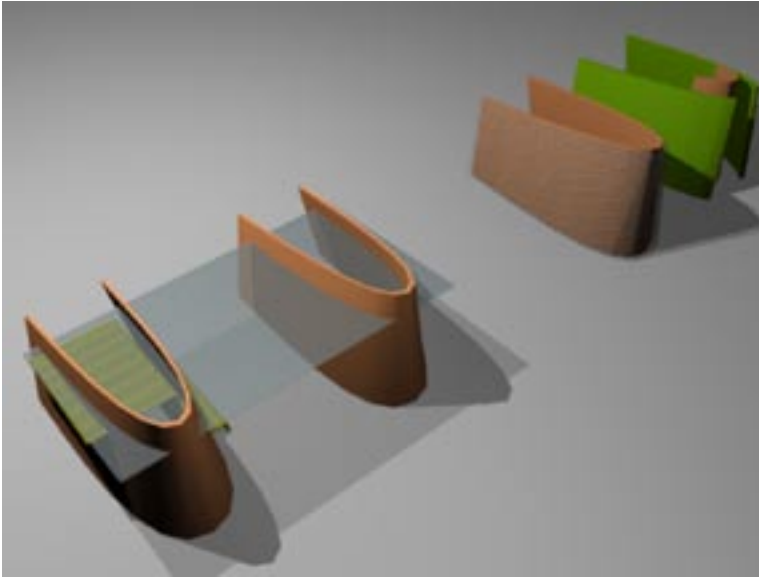
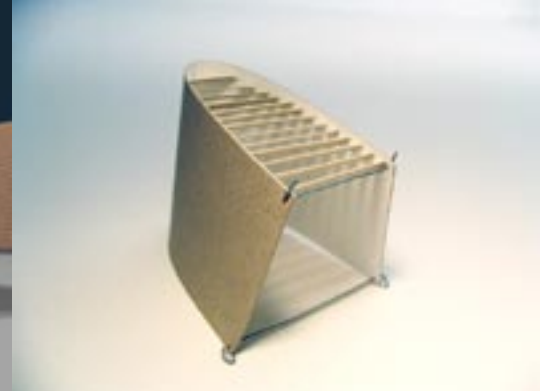
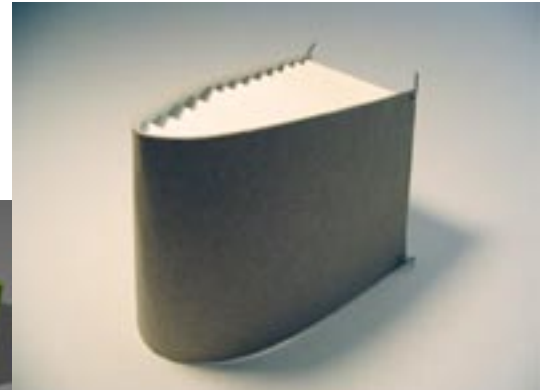
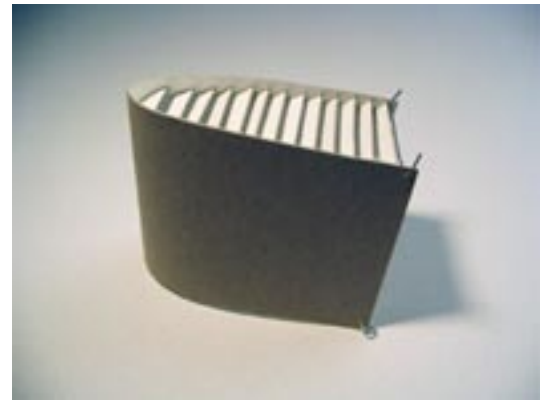

Gratiot Steam Washroom Study

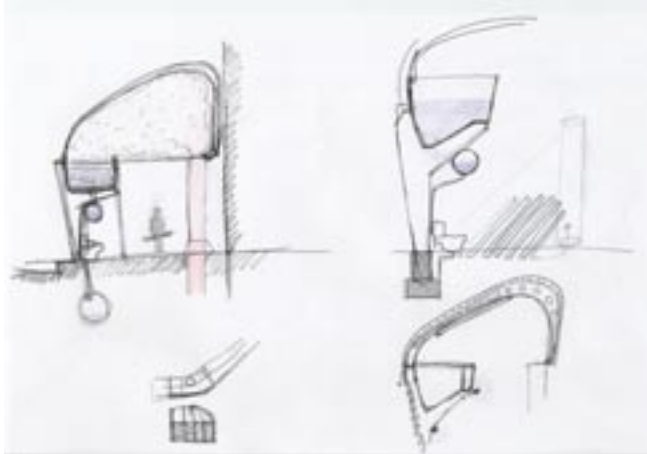
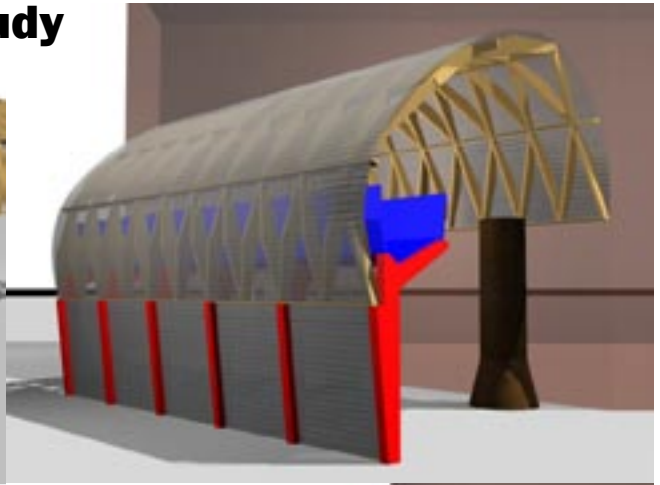
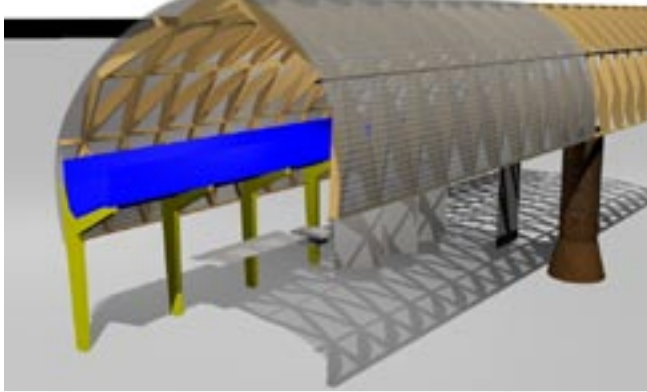

steam pipe in front of building is harnessed for its water and heat. the heat is trapped by a canopy that is attached to the wall of the building and then the vapour condenses and is stored for the toilets.

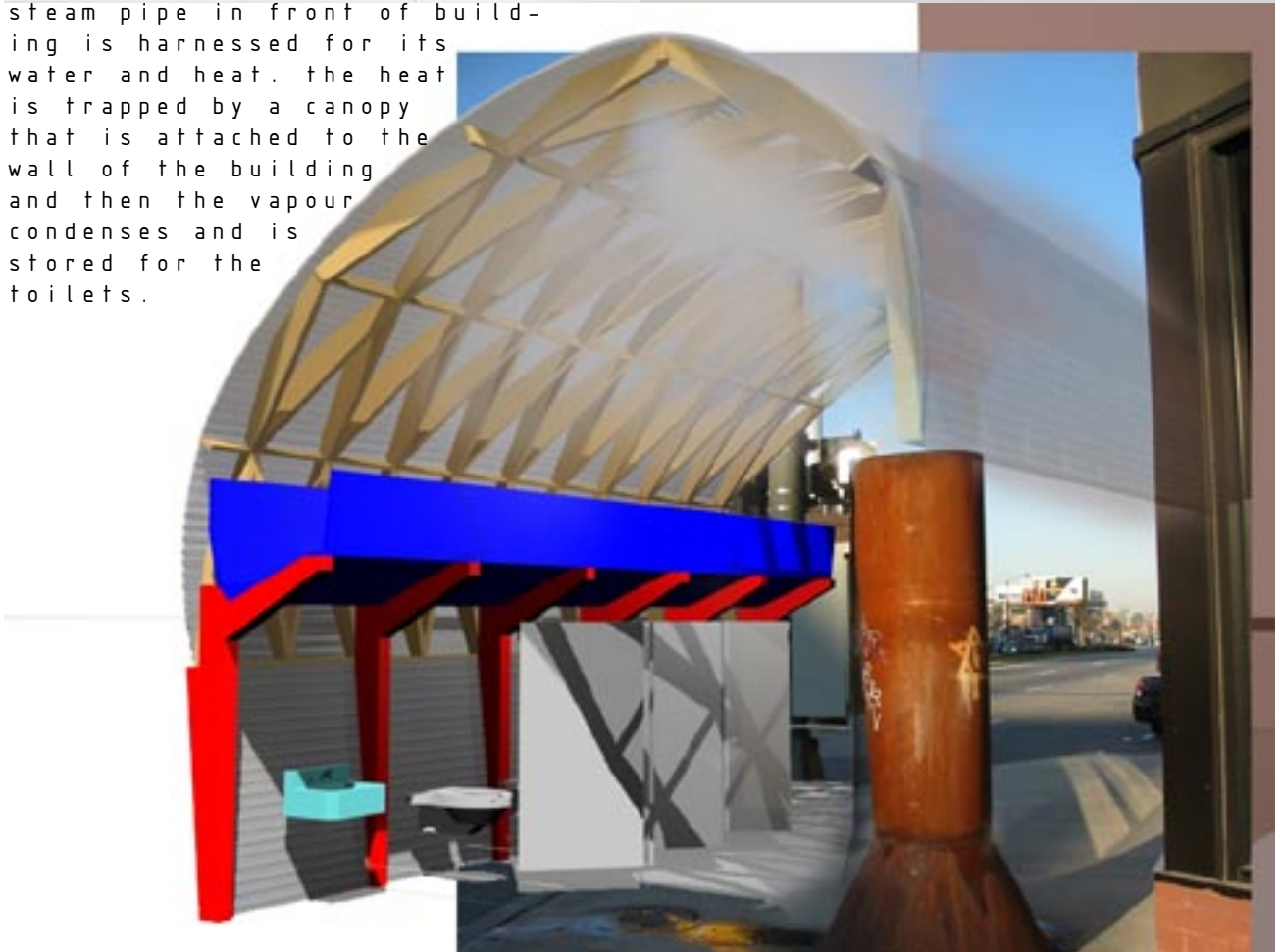

Tube Structure Studies

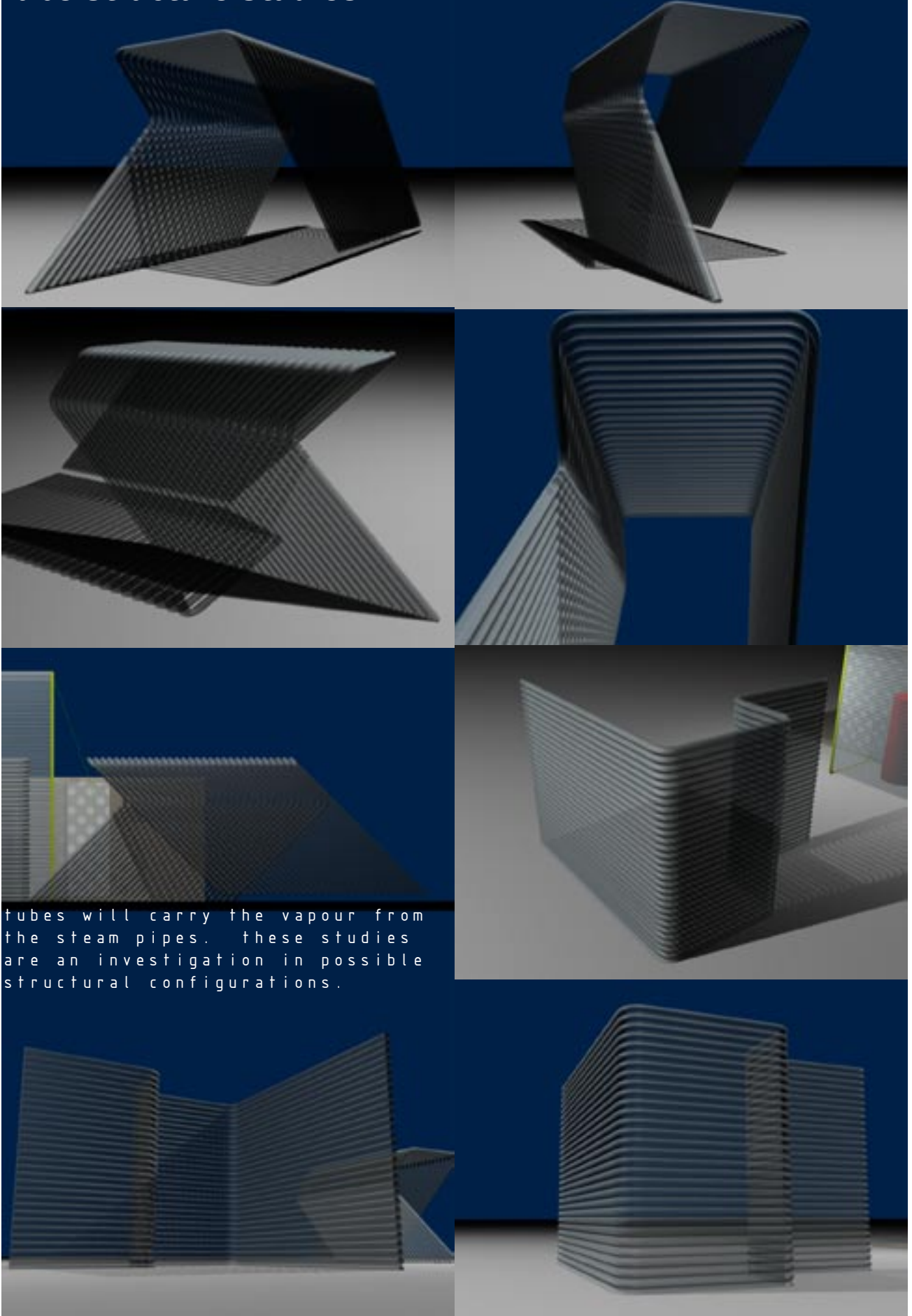

tubes will carry the vapour from the steam pipes. these studies are an investigation in possible structural configurations.

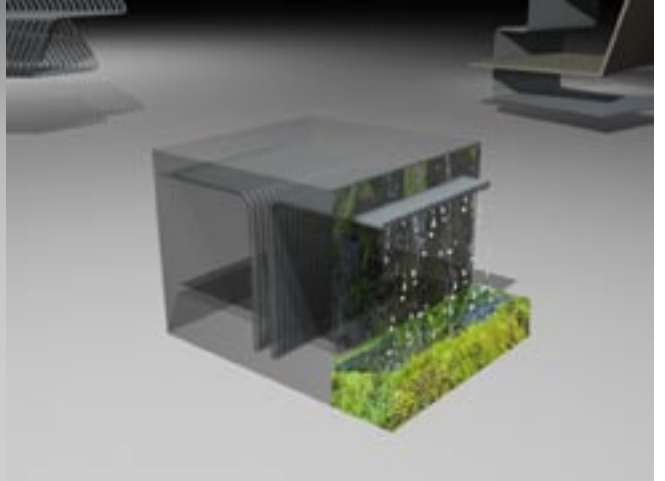
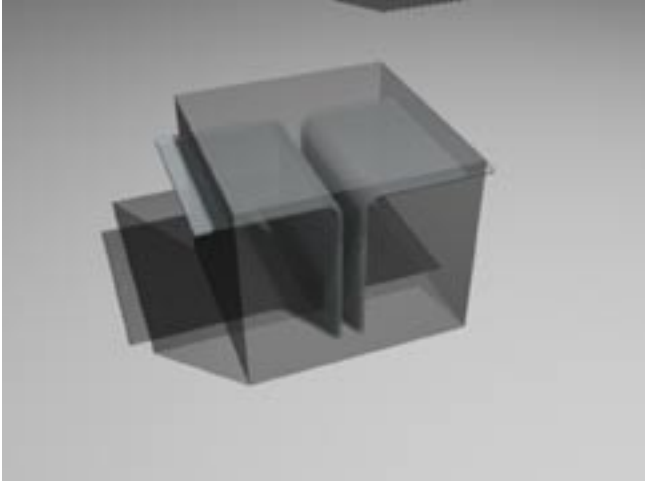
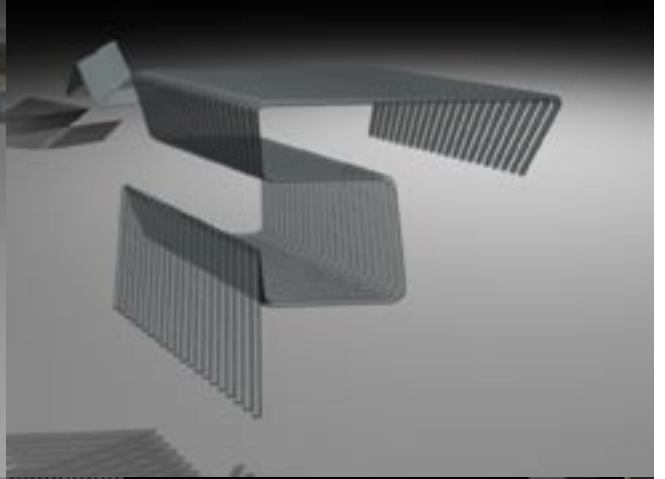
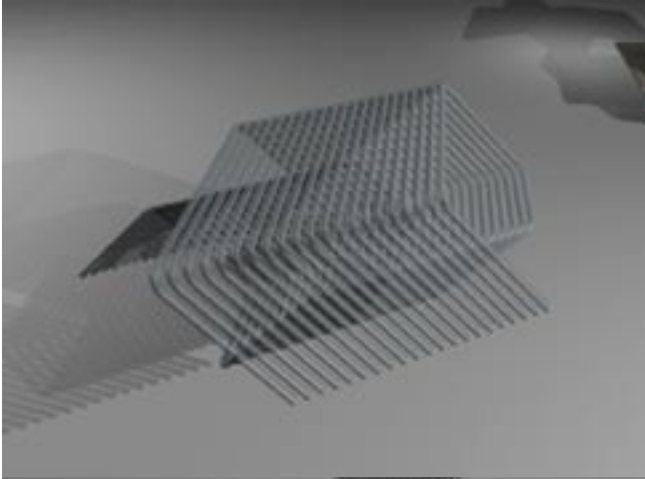
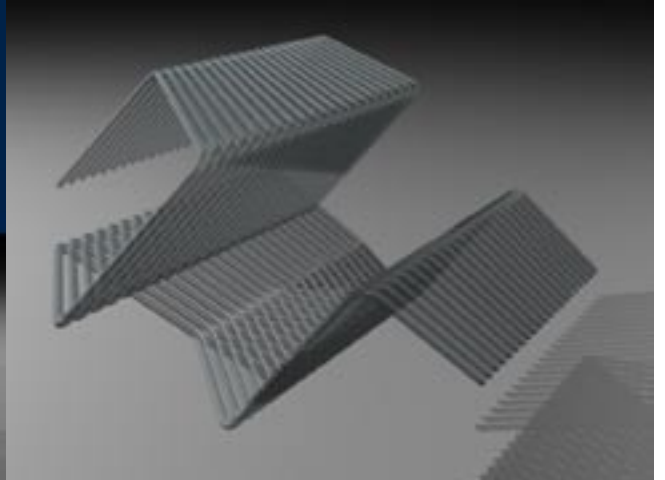
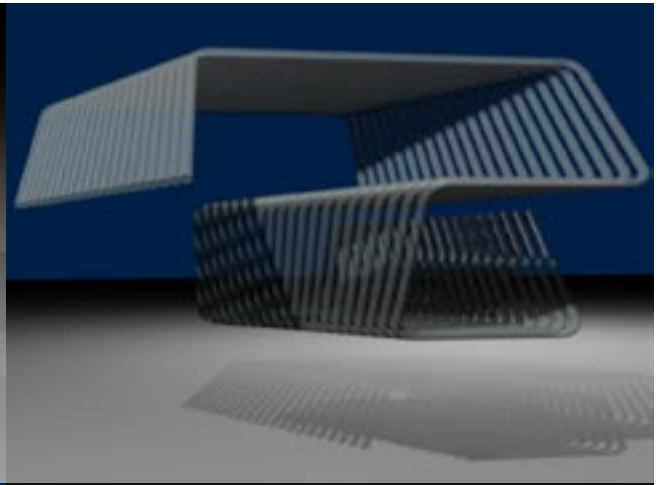
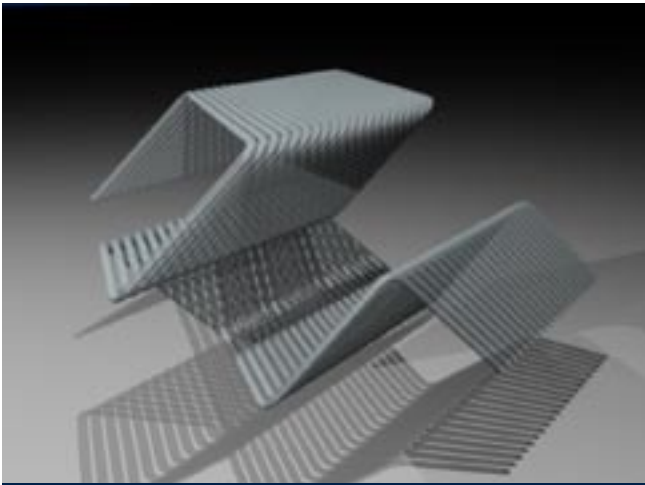

Tube Structure Studies

combining tubes with more "concrete" structure.

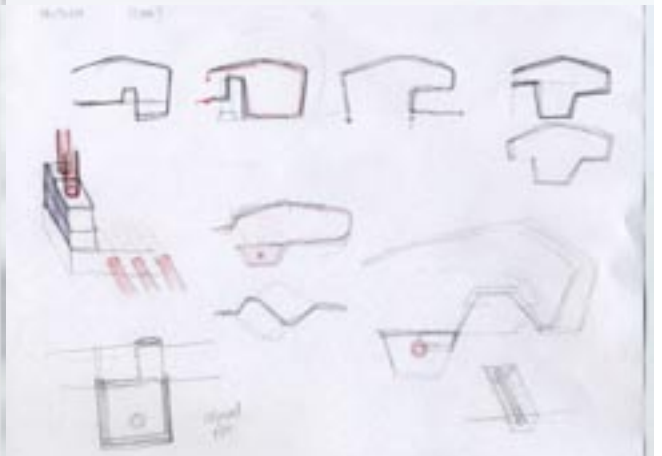
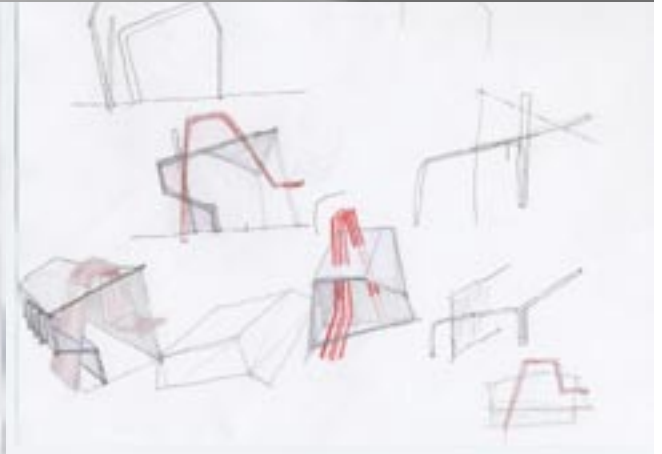
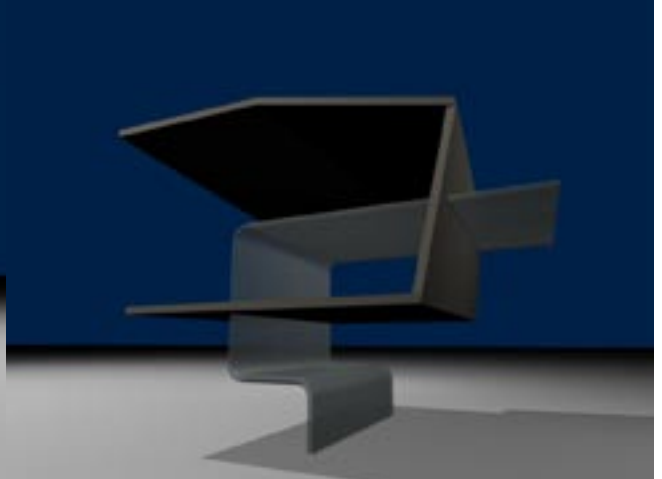
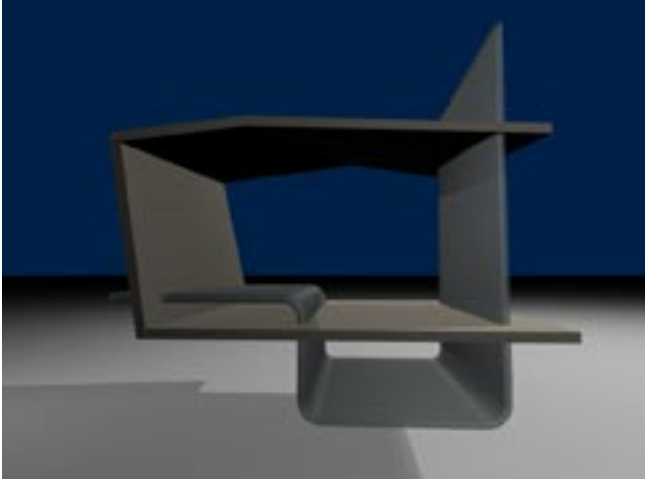
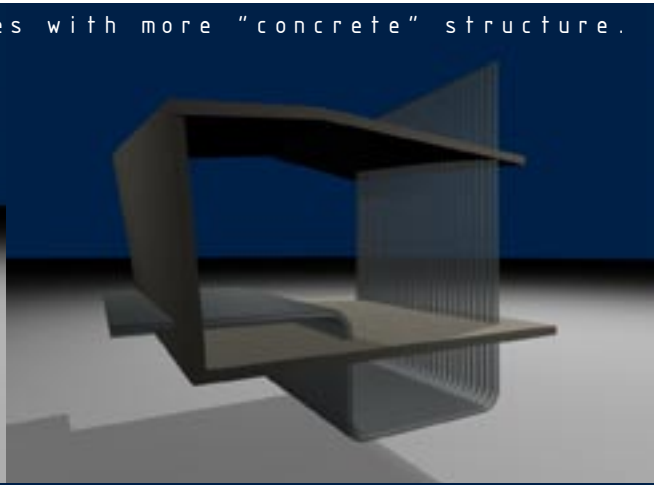
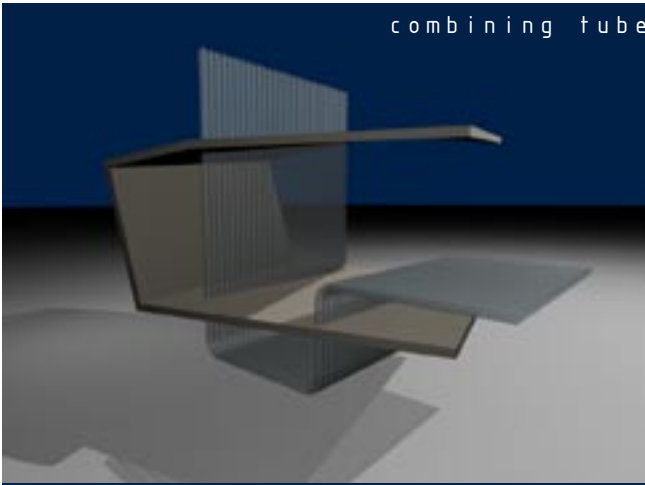

Canopy Studies

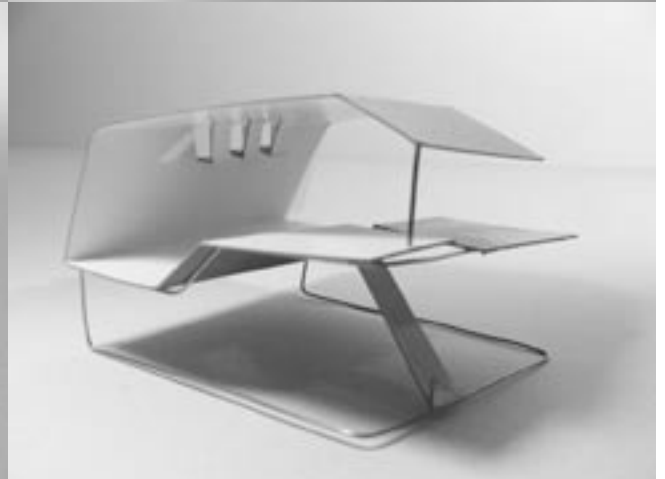
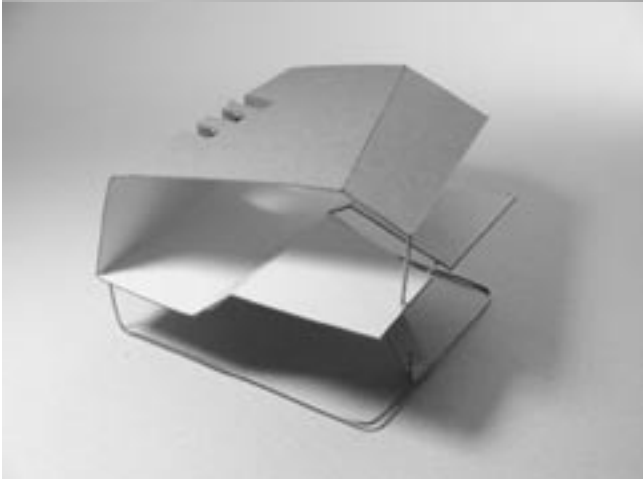
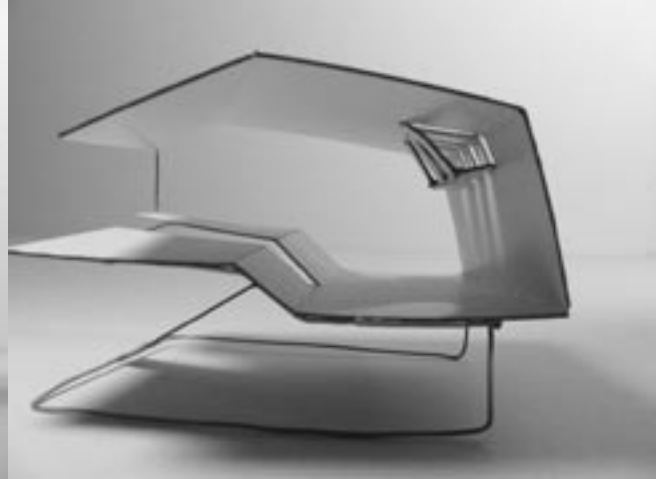
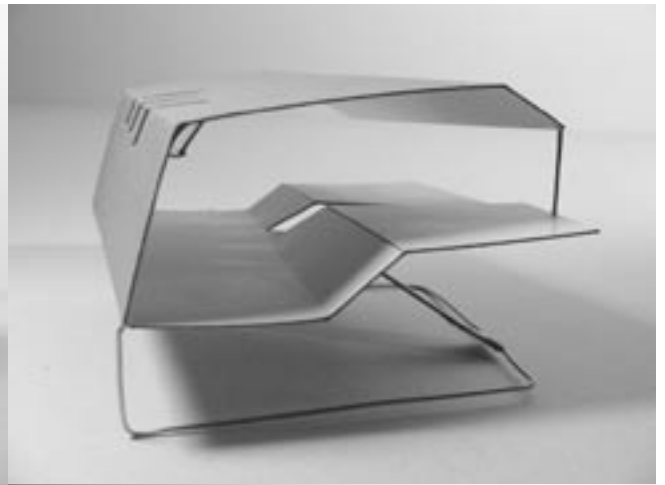
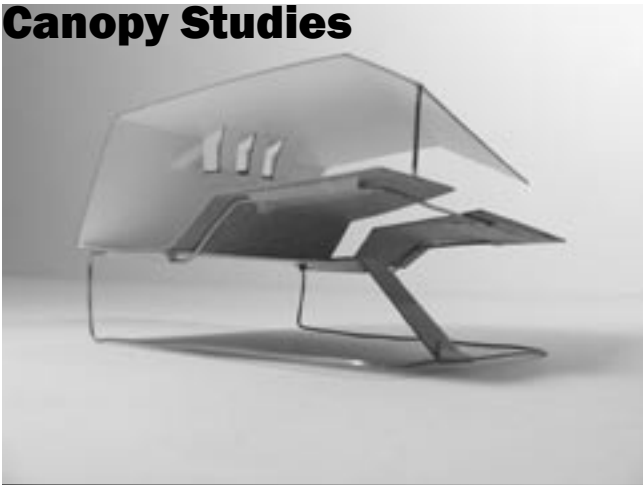

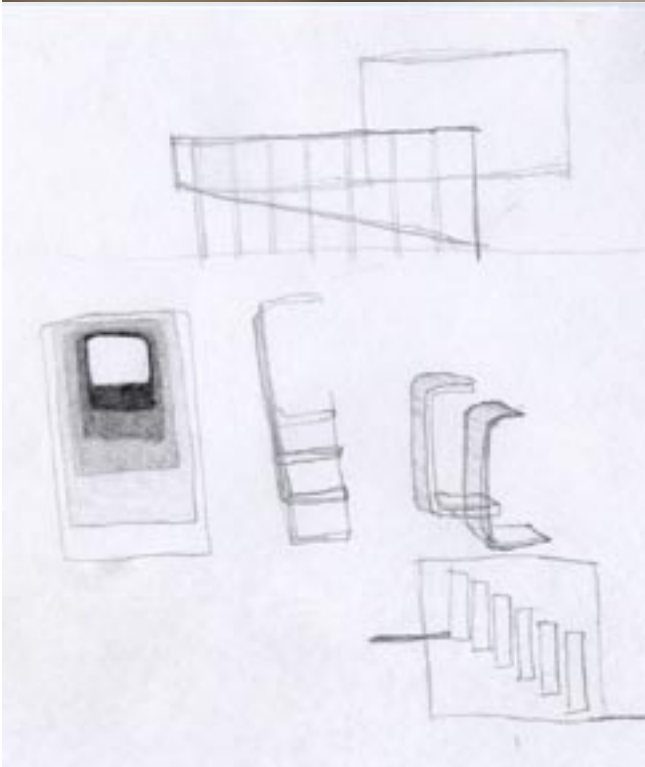
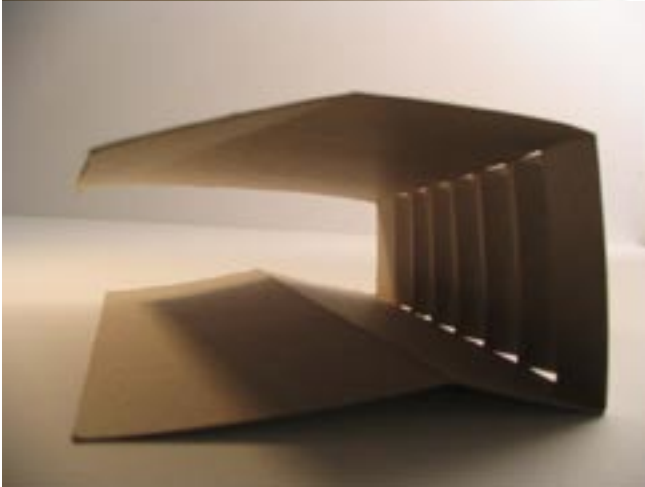

Tube Structure Studies

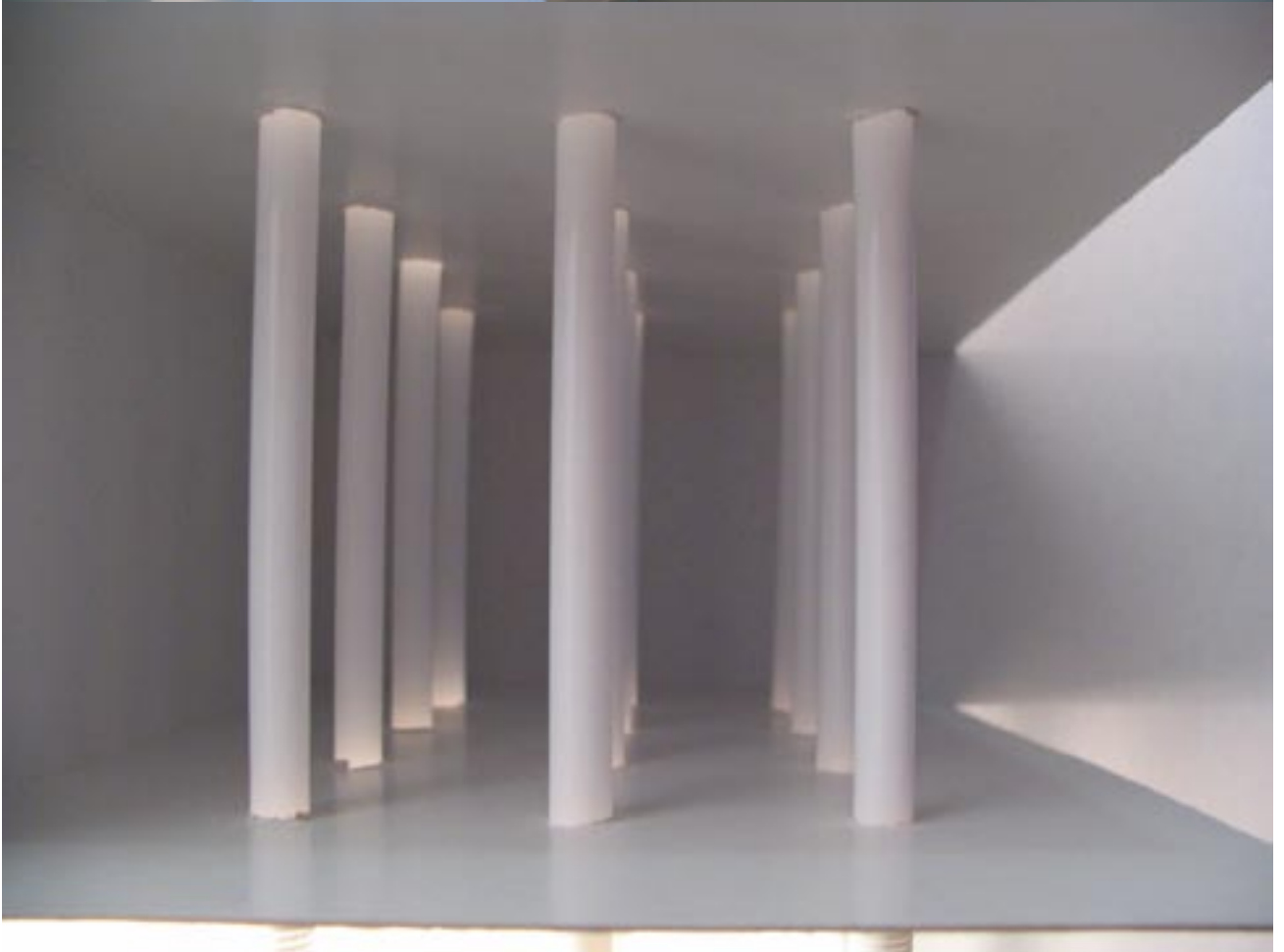
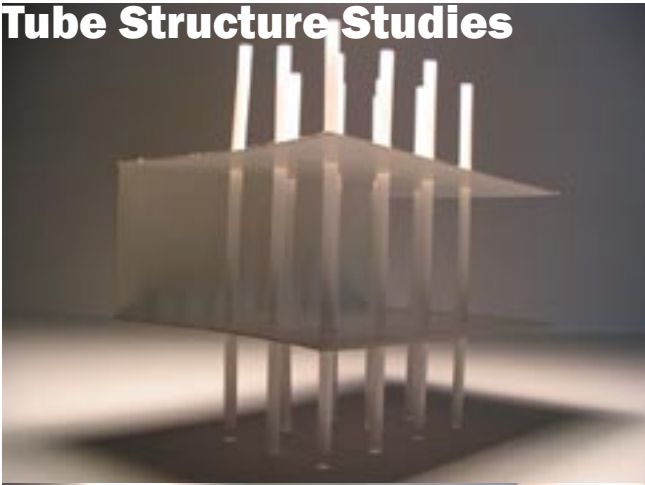

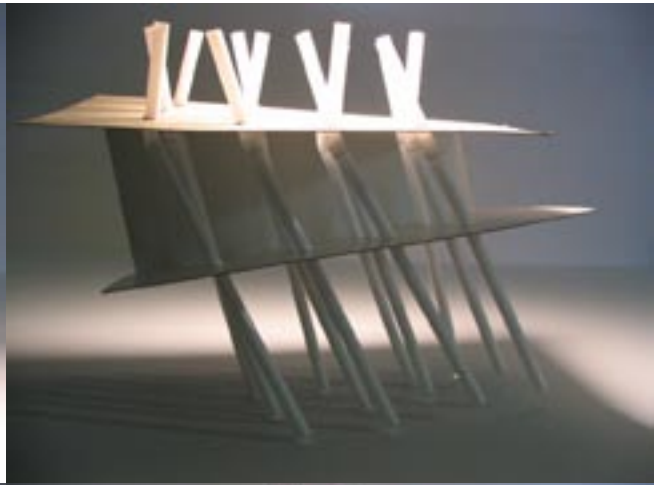
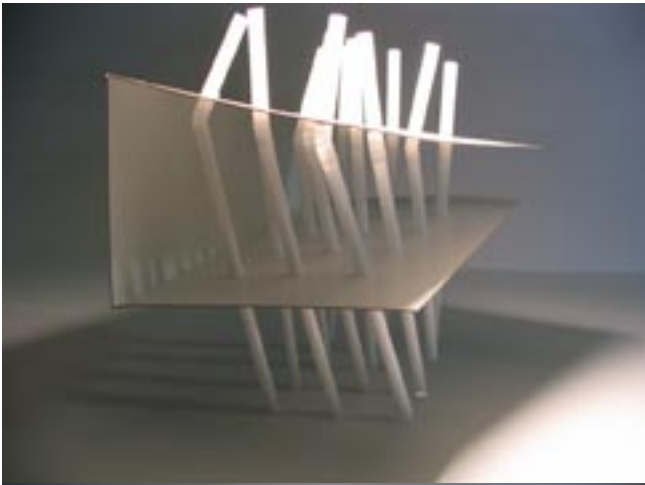

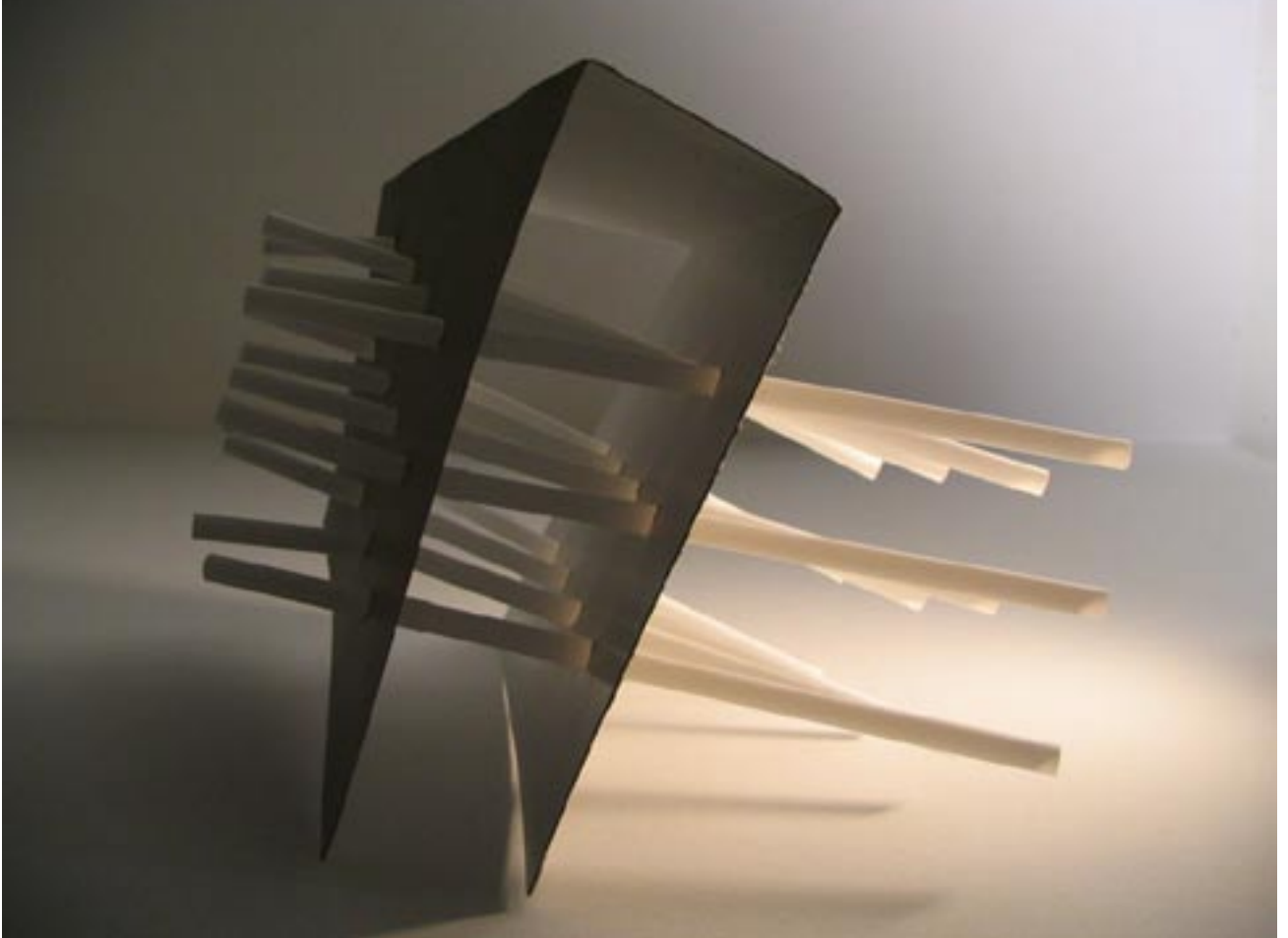
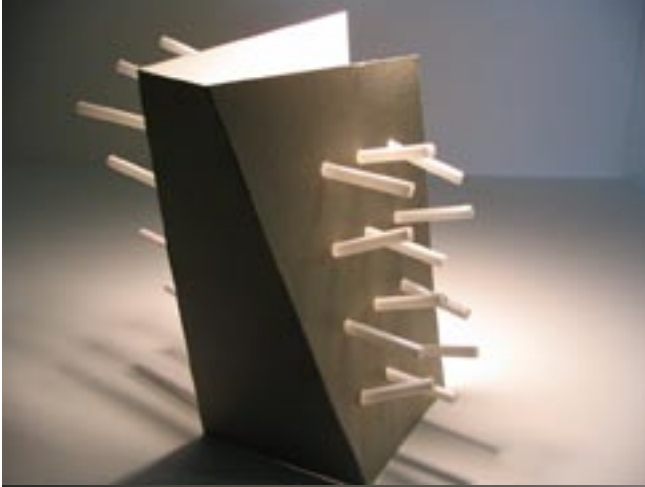
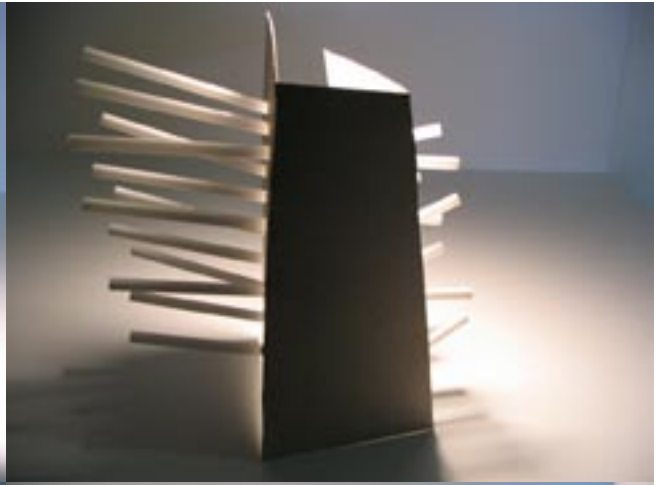
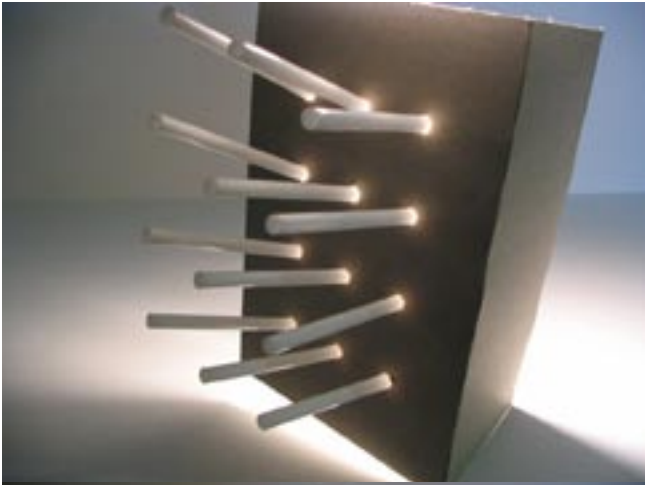

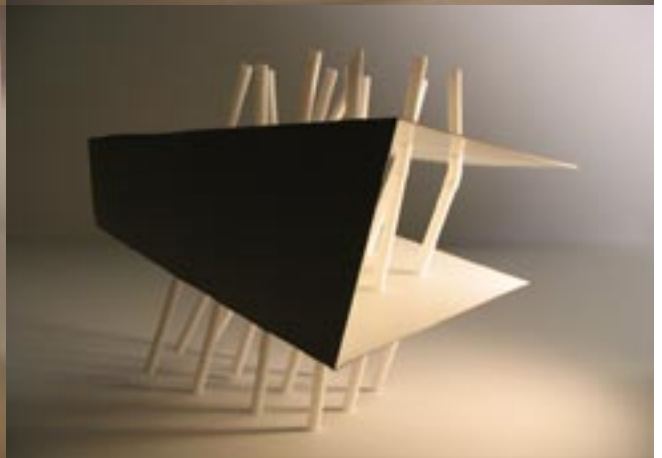
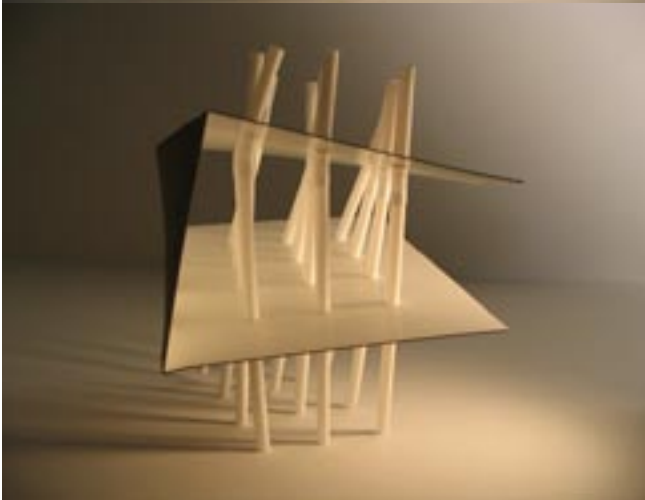
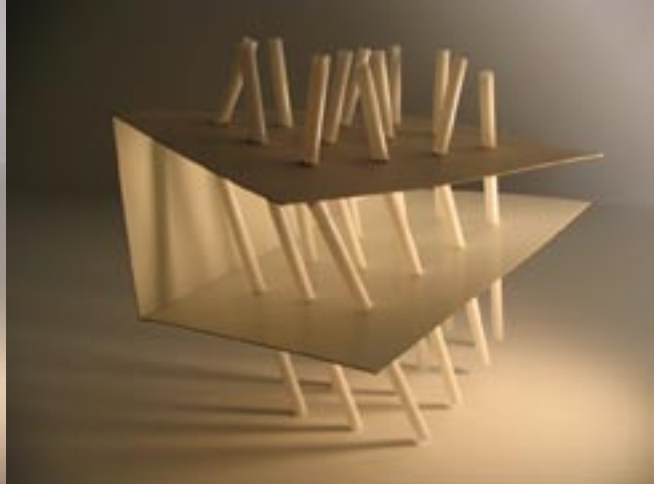
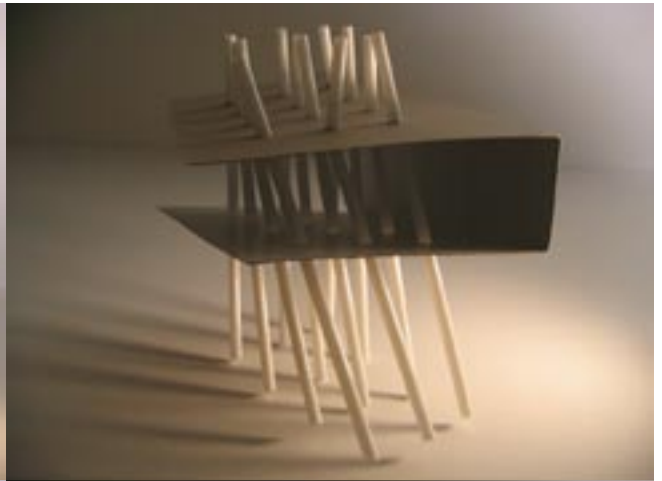

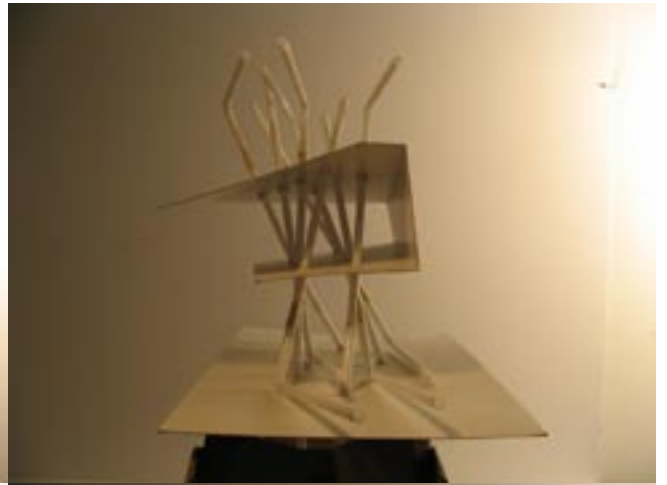
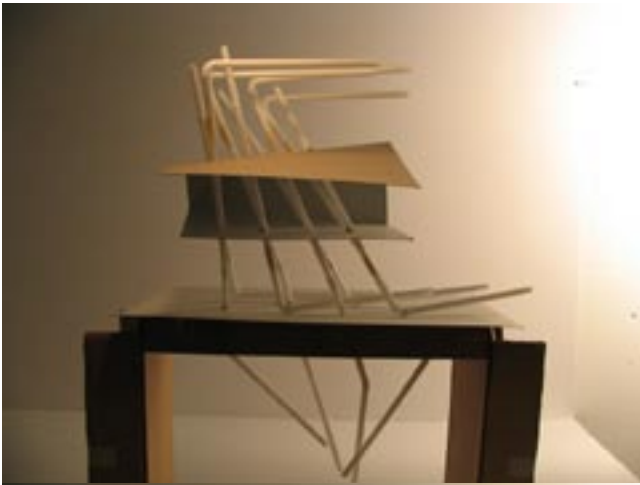

pipes connect to underground steam system to diffuse heat throughout structure.

Bus Stop Sketches

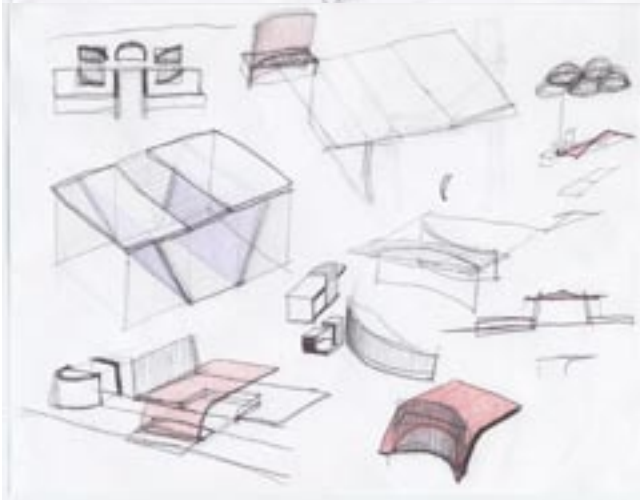
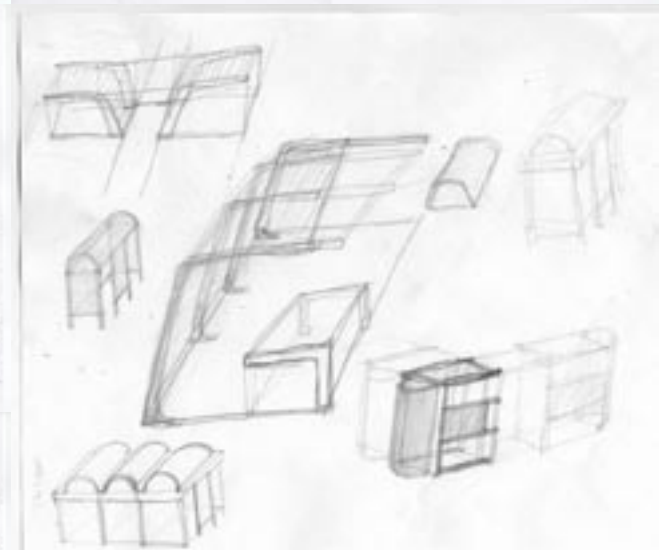
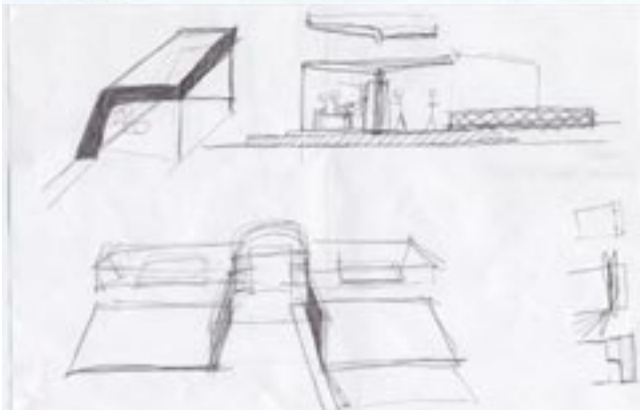
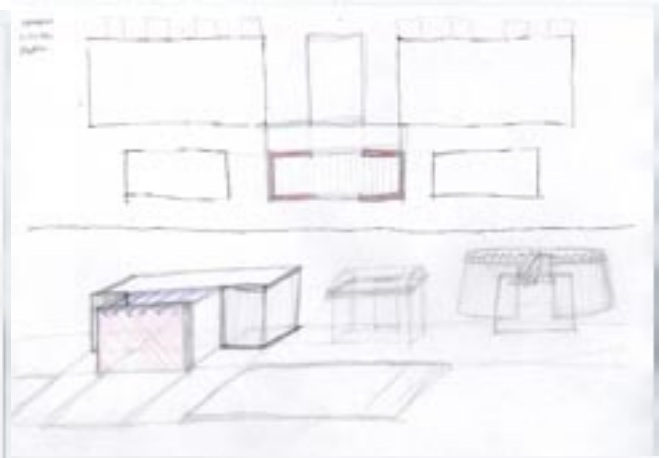
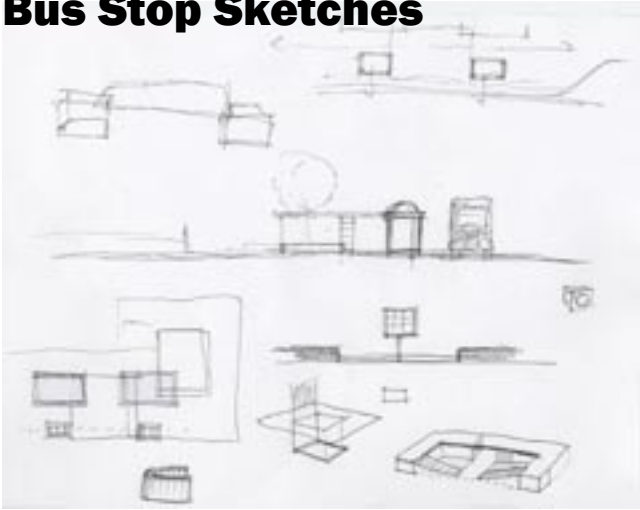

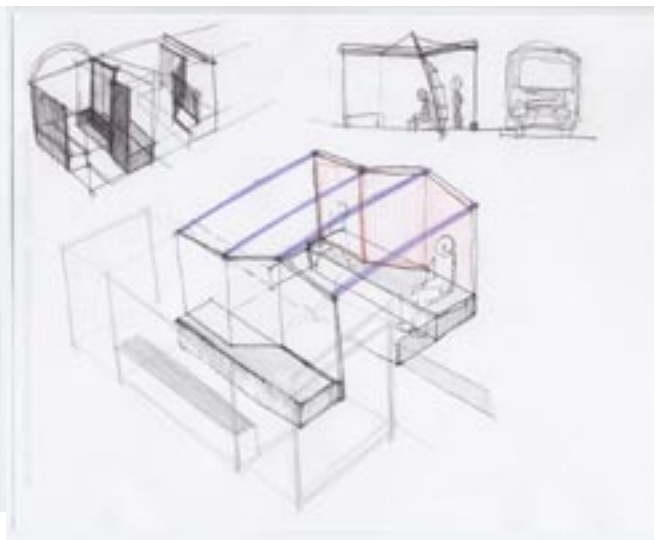
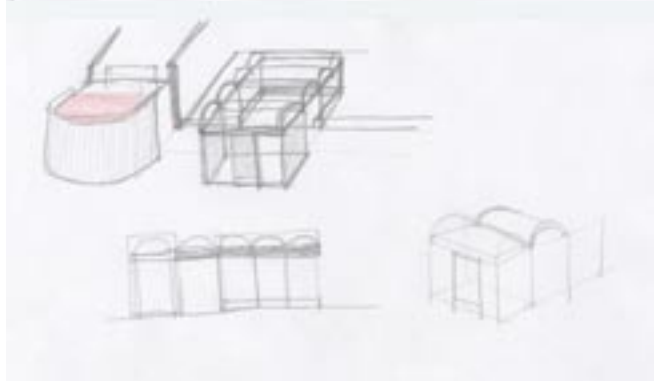
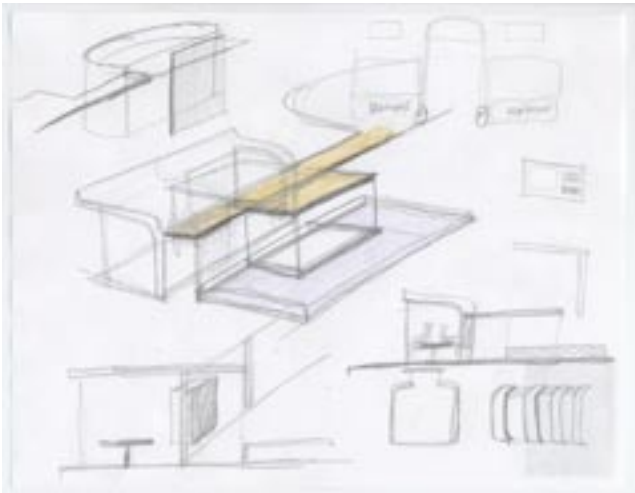
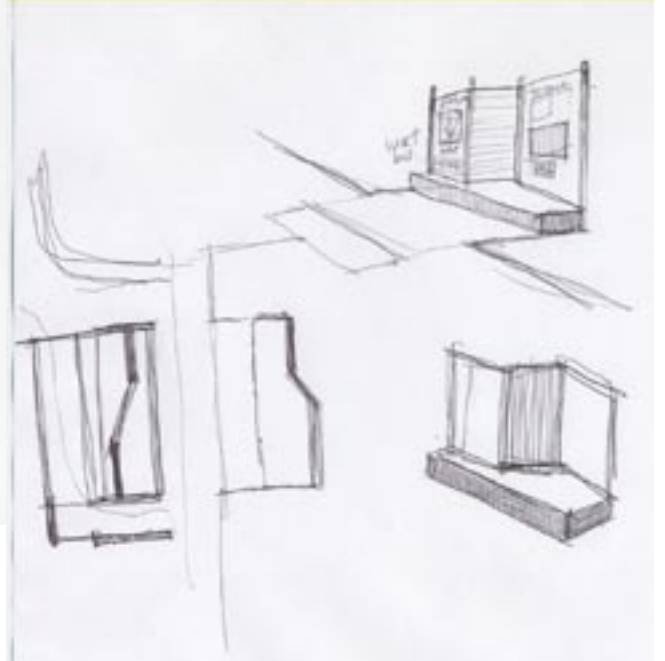
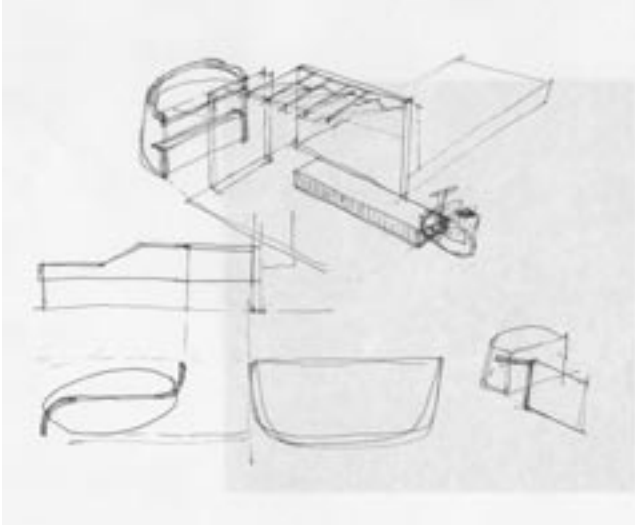

Griswold Car Wash Sketches

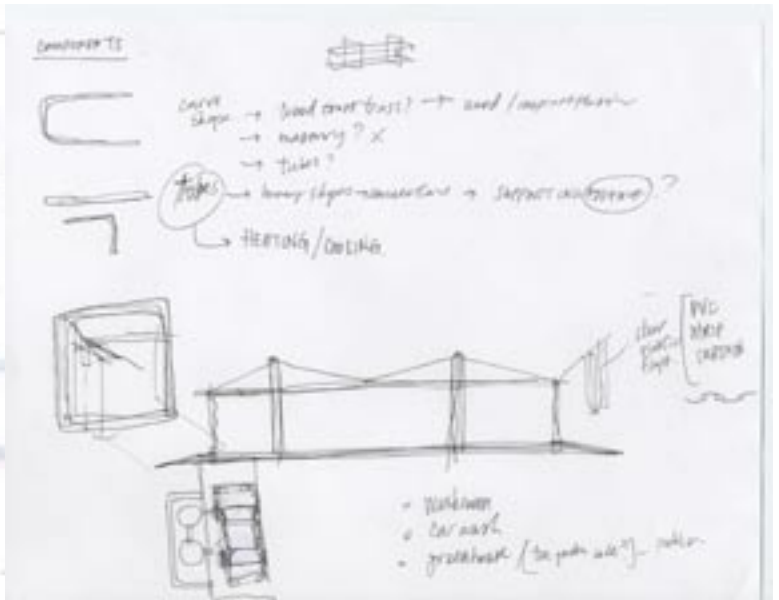
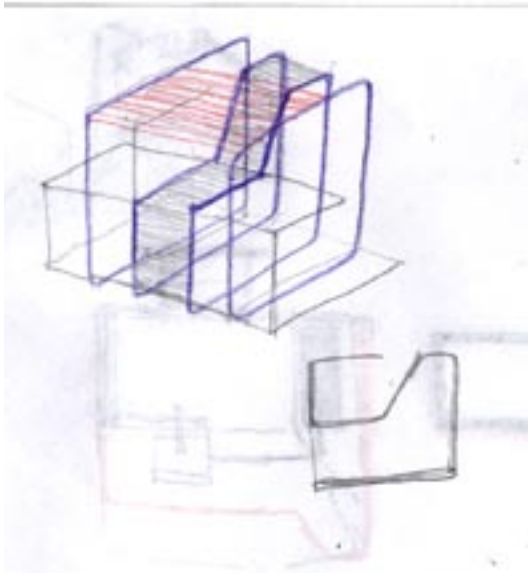

SITE PLAN STUDY
 although a series of parking and island arrangements can be organized on the site, the informal way that traffic automatically responds to the site conditions is more interesting.

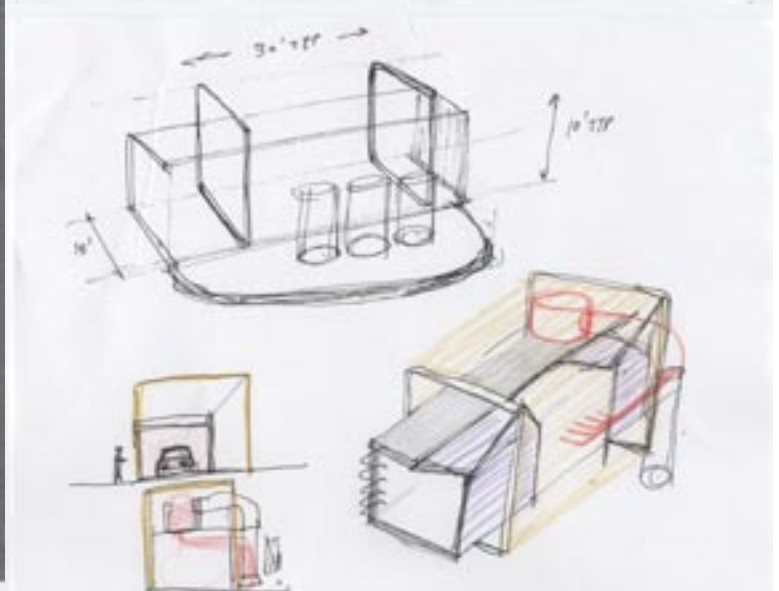
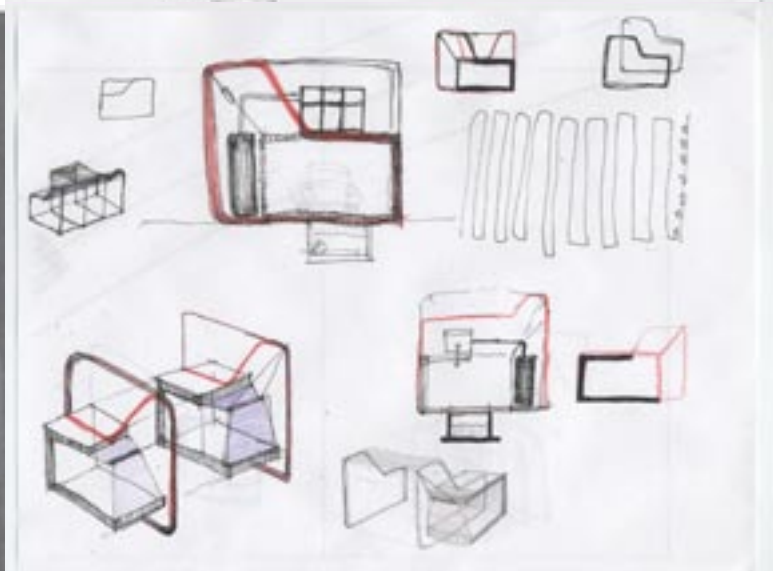

Garden Station Park Sketches

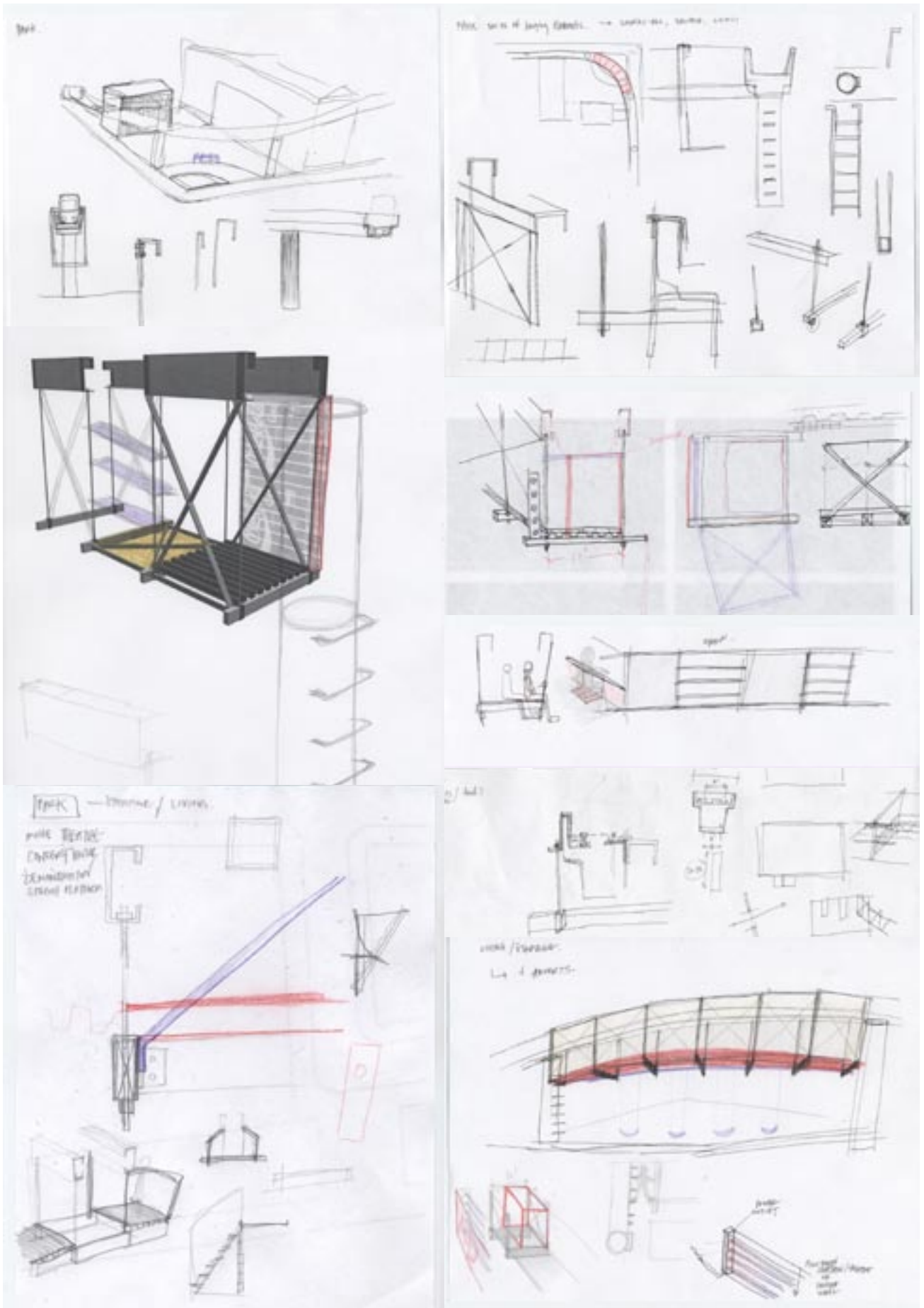

Garden Station Park Sketches

